



Contents

1. Company Details.....	3
2. Health and Safety Information.....	4
2.1 Personal Protective Clothing.....	4
2.2 Consideration of Technical Risk.....	4
3. Design.....	5
3.1 General Considerations.....	5
3.2 Optimum heat recovery performance.....	5
4. Product Description.....	6
5. How to use this manual.....	6
6. System Components.....	9
7. System Component Orientation.....	10
8. Parts List.....	11
9. Flat Roof Applications.....	14
9.1 Prepare Roof Opening.....	14
9.2 Prepare Upstand.....	15
9.3 Drain gutter clearance cut-out.....	16
9.4 Installing the Heat Exchanger.....	17
9.5 Fitting the Cowl.....	19
10. Flat Roof - Extended Height Applications.....	21
10.1 Prepare Roof Opening.....	21
10.2 Prepare Upstand.....	22
10.3 Drain gutter clearance cut-out.....	23
10.4 Installation of Skirt Extension.....	24
10.5 Installing the Heat Exchanger.....	25
10.6 Fitting the Cowl.....	27
11. Pitched Roof Applications.....	29
11.1 Prepare Roof Opening.....	29
11.2 Prepare Upstand.....	30
11.3 Drain gutter clearance cut-out.....	31
11.4 Installation of Skirt Extension.....	32
11.5 Extensions Pieces.....	33
11.6 Installing the heat exchanger.....	34
11.7 Fitting the Cowl.....	36

12. Installing the Internal Diffuser.....	38
12.1 Internal Diffuser Installation.....	38
12.2 Installing Absorption Bag.....	41
13. Installing Ceiling Mounted Diffuser Box.....	42
13.1 External Diffuser Box.....	42
13.2 Fitting the External Diffuser Box.....	42
13.3 Fully Assembled Exernal Diffuser.....	44
14. Installing the Plenum Box for Ducted System.....	45
14.1 Fitting the plenum box assembly.....	45
15. Ducting Details.....	47
15.1 Ducting Installation.....	47
15.2 Duct Variants.....	48
16. Ventive Hub Controls.....	49
16.1 CO2 Sensor.....	50
16.2 External Temperture Sensor.....	52
16.3 Wiring Detail.....	53
17. Post - installation Checklist of Ventive Windhive.....	54
17.1 Above Roof.....	54
17.2 Below Roof.....	54
17.3 Ducted – Within Building Envelope.....	54
18. Commissioning.....	55
19. Installer Details.....	55

1. Company Details

Ventive Ltd
Thames House
Swan Street
Isleworth
TW7 6RS

Contact:
Tel: 02085601314
Email: contact@ventive.co.uk
Website: www.ventive.co.uk

2. Health and Safety Information

Before installation of the Ventive Windhive units can commence, it is essential that all installers have valid CSCS cards and all other relevant qualifications.

2.1 Personal Protective Clothing

PPE must be worn at all times while on site which include

- Hard Hats
- Gloves
- Eye Protection
- Steel Toe Cap Boots
- High Visibility Jackets

*Lifting harness may be required dependent on-site rules.



Installation of Ventive Windhive involves working at height and installers must comply with the *Work at Height Regulations, 2005*. As part of the Regulations it must be ensured that:

All work at height is properly planned and organised;

Those involved in work at height are competent and authorised;

The risks from work at height are assessed and correct work equipment is selected and used;

The risks from fragile surfaces are properly controlled; and

Equipment for work at height is properly inspected and maintained.

For detailed guidance please refer to *"Health and safety in roof work", 2012, HSE*.

Ventive Ltd accepts no liability resulting from injury, loss or damage caused by inappropriate workmanship on site.

2.2 Consideration of Technical Risk

Installation of Ventive Windhive should be completed in accordance with this manual. Any changes to the installation process should be approved by Ventive Technical Support (see contact details on the last page).

Installation works are to be conducted by competent individuals with roofing experience and preferably trained by Ventive and only with originally supplied parts, or products recommended by Ventive Technical Support. Installation should not interfere with other construction elements or services within the building.

Non-compliant installation voids the warranty and Ventive Ltd takes no responsibility for any loss or damage caused by incorrect installation and use of the system.

3. Design

3.1 General Considerations

1. Duct sizes and types should be in accordance to this manual or following advice from Ventive Technical Support.
2. Use of horizontal duct runs is not recommended apart from the final leg of either supply or extract directly connecting to the room inlet/outlet. In such a scenario the maximum length should be less than 300mm for the extract and the supply.
3. It is recommended that all ducts are installed within heated or insulated spaces. When in unheated or exposed areas the ducts should be separately insulated.
4. Each extract duct is to be connected separately to the air flow Splitter; the supply duct is to be terminated at low level (400mm maximum recommended distance above the floor).
5. Each Ventive Windhive has a condensation pipe outlet mounted on the flow splitter which must be connected to a 21mm overflow pipe complete with a deep seal trap and drained appropriately. If this is not possible, condensation management system is available as optional.
6. The Windhive unit incorporates a water run off drain which exists the unit at roof level

3.2 Optimum heat recovery performance

To maximise the benefits of heat recovery, Ventive Windhive should be used in buildings with air permeability of $5\text{m}^3/(\text{h}\cdot\text{m}^2 @ 50\text{Pa})$ or better; If this is not achieved an increased proportion of make-up air will be provided by infiltration, reducing the overall energy saving. Please seek further advice from our Technical Support when designing ventilation for buildings with airtightness better than $1\text{ m}^3/(\text{h}\cdot\text{m}^2 @ 50\text{Pa})$.

The use of trickle vents is not recommended when installing Ventive as all incoming air should be handled by the system. Unless our purge ventilation option is chosen in which case an actuated louvre will be provided.

4. Product Description

Ventive Windhive is a Natural Ventilation System with Heat Recovery. It is designed to provide continuous ventilation for schools and commercial buildings during occupied hours, without the use of electricity, while recovering heat from the outgoing stale air.

Ventive utilises a combination of air buoyancy and wind to provide ventilation, maintaining good indoor air quality at all times. When installed correctly, Ventive Windhive can recover up to 75% of heat from the outgoing air, improving occupant comfort and reduces heating costs.

Ventive Windhive is designed to fit through the roof. As a modular solution it offers a level of flexibility, with the number of systems tailored to the building size and type.

The system has three external variants available depending on the roof type which are for flat roof application, flat roof application with extended height or pitched roof application.

Internally the system has three variants depending on the design of the building. The Windhive can either be ducted down to multiple floors, ducted to a suspended ceiling or have an in-room diffuser.

5. How to use this manual

This manual has been designed to assist with installation of the Ventive Windhive. It contains detailed drawings and instructions. There are three different variations depending on roof type and roof height.

Please follow the below options depending on the configuration you require.

Option 1: Flat Roof Application

Sections required for installation:

- 5. System Components
- 6. System Component Orientation
- 7. Parts List
- 9. Flat Roof Applications
- 12. Installing the Internal Diffuser

Please see page 7 for Ducted system or Ceiling Mounted system options.

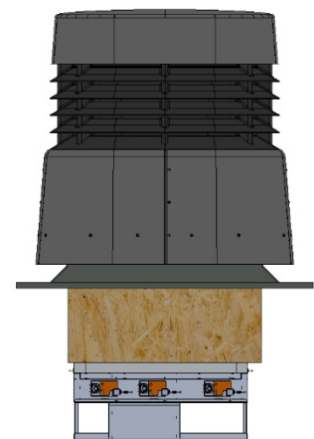

Figure 1 – Flat roof option.

Option 2: Flat Roof Application with Extended Height

Sections required for installation:

- 5. System Components
- 6. System Component Orientation
- 7. Parts List
- 10. Flat Roof – extended height required application
- 12. Installing the Internal Diffuser

Please see page 7 for Ducted system or Ceiling Mounted system options.



Figure 2 – Flat Roof Application with extended height

Option 3 : Pitched Roof Application

Sections required for installation:

- 5. System Components
- 6. System Component Orientation
- 7. Parts List
- 11. Pitched Roof Applications
- 12. Installing the Internal Diffuser

Please see page 7 for Ducted system or Ceiling Mounted system options.

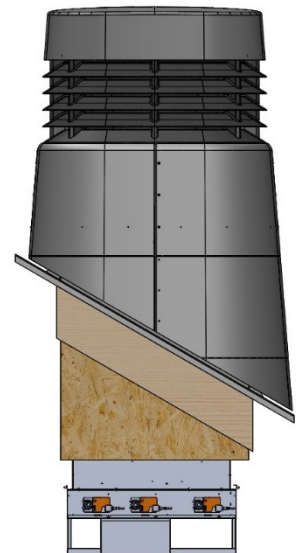

Figure 3 – Pitched Roof Option.

Note: The following extension pieces will be preassembled to the bottom of the heat exchanger housing based on the roof pitch below.

PITCHES OF 9°- 20° = SINGLE 250MM EXTENSION DUCT

PITCHES OF 21°- 30° = SINGLE 500MM EXTENSION DUCT

PITCHES OF 31- 40° = SINGLE 250MM & 500MM EXTENSION DUCT

PITCHES OVER 40° WILL A REQUIRE BESPOKE SKIRT. PLEASE CONTACT VENTIVE FOR INFORMATION.

In Room Ceiling Mounted Option:

If you are installing a ducted system, please go to Sections once you have completed the installation of the internal diffuser.

Sections required for installation:

13. Installing Ceiling Mounted Diffuser Box

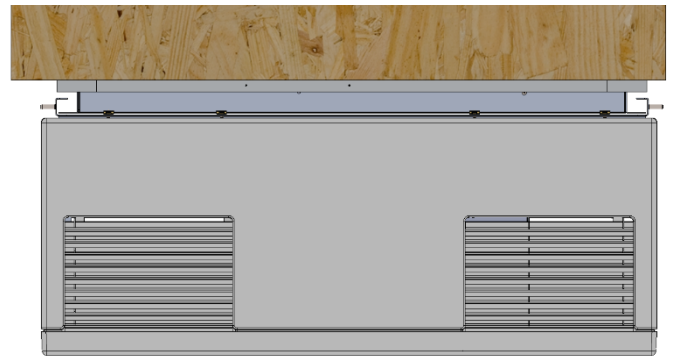

Figure 4 - Ceiling mounted option.

Ducted System Option:

If you are installing a ducted system, please go to Sections once you have completed the installation of the internal diffuser.

Sections required for installation:

14. Installing the Plenum Box for Ducted System

15. Ducting Details

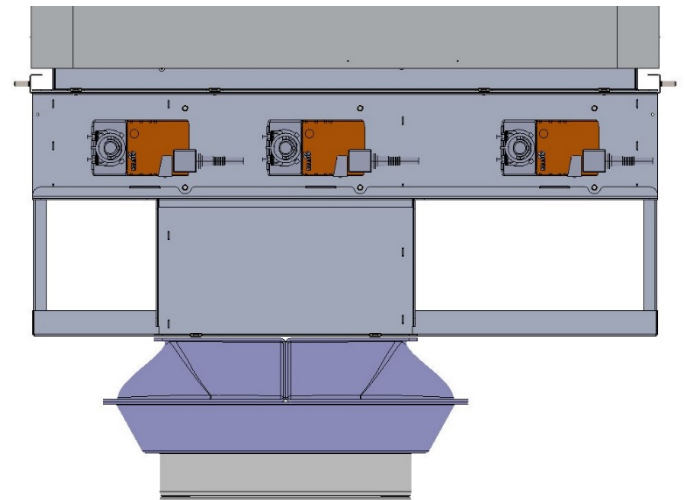

Figure 5 -Ducted installation option.

6. System Components

In the image below you can see an exploded assembly of the Ventive windhive. It shows all of the system components of the windhive system.

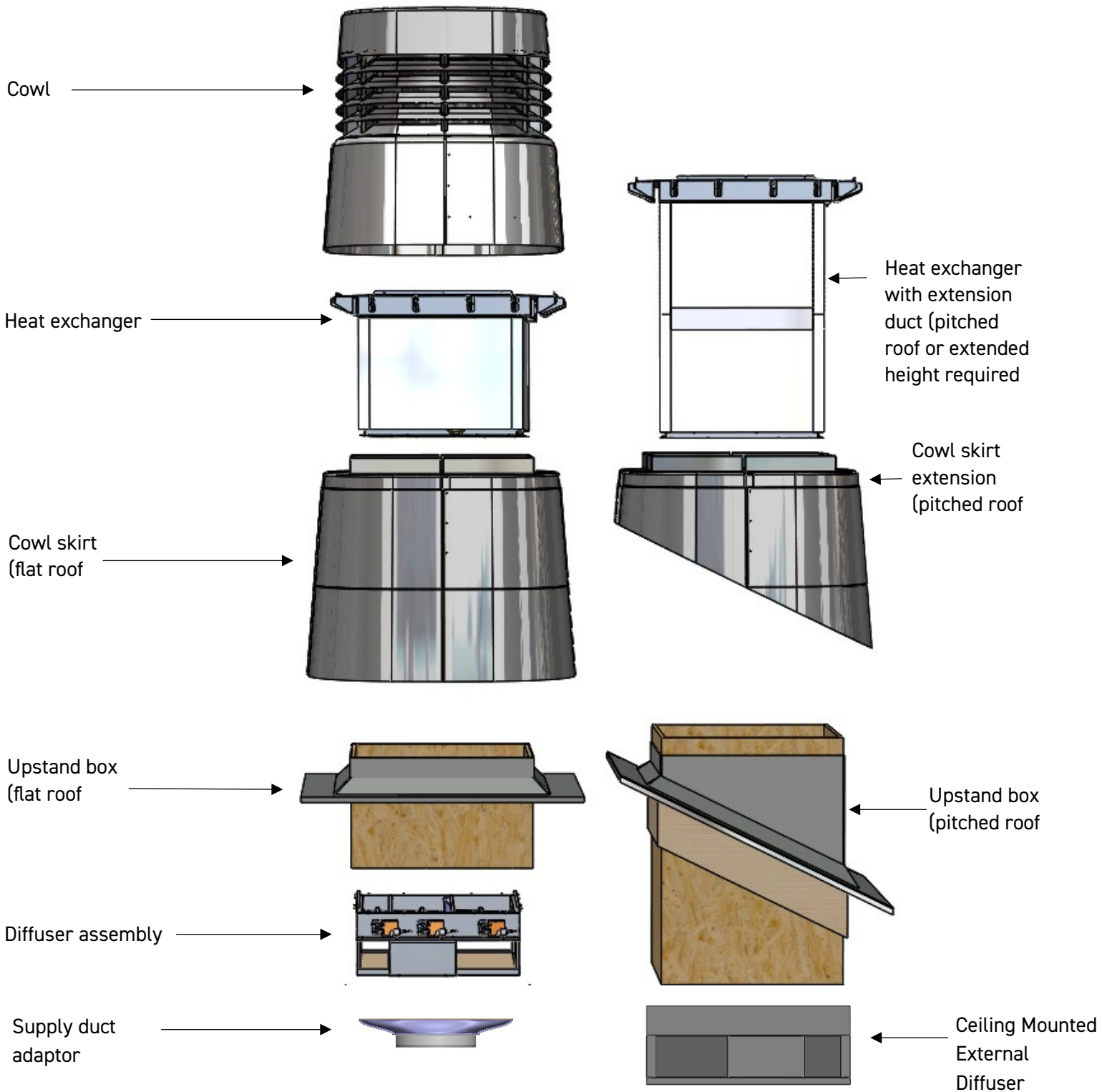

Figure 6 - System component breakdown.

7. System Component Orientation

Ensure that all of the arrow label on each assembly are aligned within the same plane during installation. The unit can only be aligned in one orientation.

Note: Arrow labels to be removed after installation.

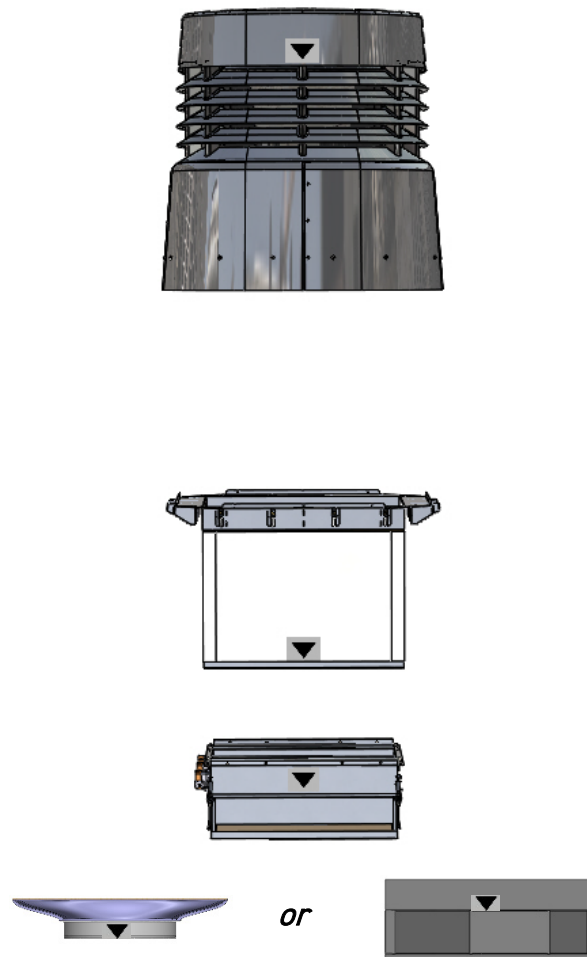
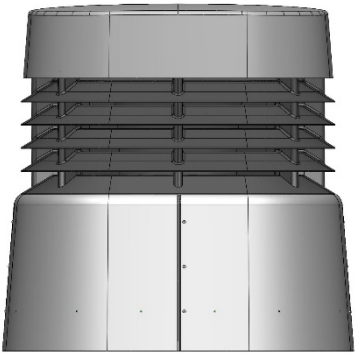
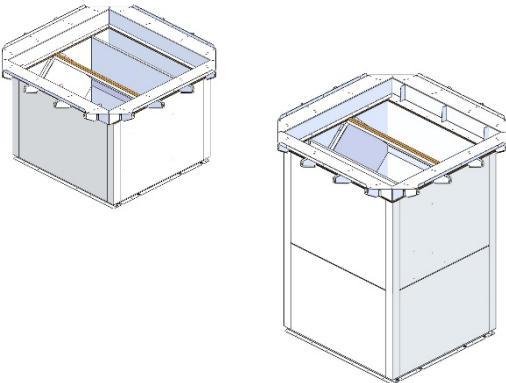
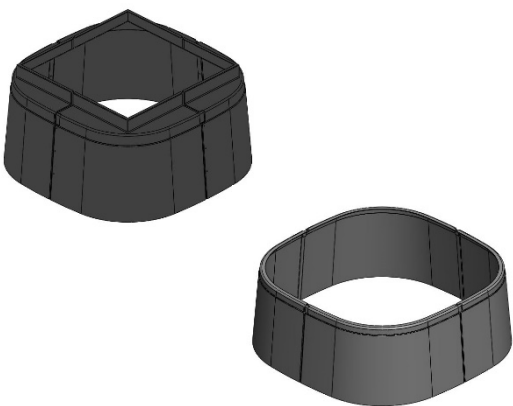
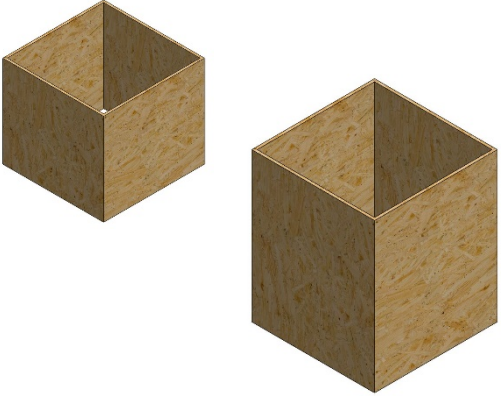
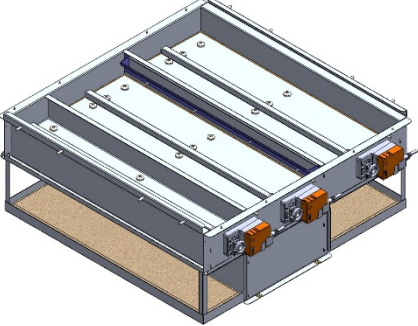

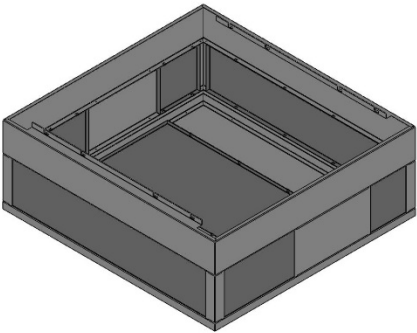



Figure 7 - Showing alignment of Windhive unit.

8. Parts List

Listed from top to bottom (as installed :

Item No:	Item	Description	QTY	Weight (Kg)
1		<i>Ventive Cowl</i>	1	43.4 kg
2		<i>Heat exchanger Standard or Extended (extended will come with 250mm or 500mm extension</i>	1	Standard: 26.5 kg Extended: 39.5 kg
3		<i>Cowl Skirt (Upper or Upper & Lower</i>	1	Upper Skirt: 9.5 kg Lower Skirt: 6.3 kg

4		<p><i>Upstand (Standard or Extended Supplied & fitted by others. Height will be specified by Ventive</i></p>	1	Depending on others
5		<p><i>Internal Diffuser assembly</i></p>	1	16.6 kg
6		<p><i>Supply duct adaptor (for ducted system Different spigot variations: 400mm/300mm/250mm</i></p>	1	200 g
7		<p><i>External diffuser housing (for ceiling mounted system</i></p>	1	5 kg

8		<p><i>Absorption Bag (1 large & 1 small)</i></p>	1 set	N/A
---	---	--	-------	-----

Note: If you are installing a ducted system we will send you a ducting schedule to advise you on the items Ventive will supply.

9. Flat Roof Applications

9.1 Prepare Roof Opening

1. Create roof opening of minimum 828mm x 828mm (*on the horizontal* - see figure 8).
2. When working with a timber roof construction ensure you use structural opening details or engineer's drawings (joints and trimmers details for clarity).

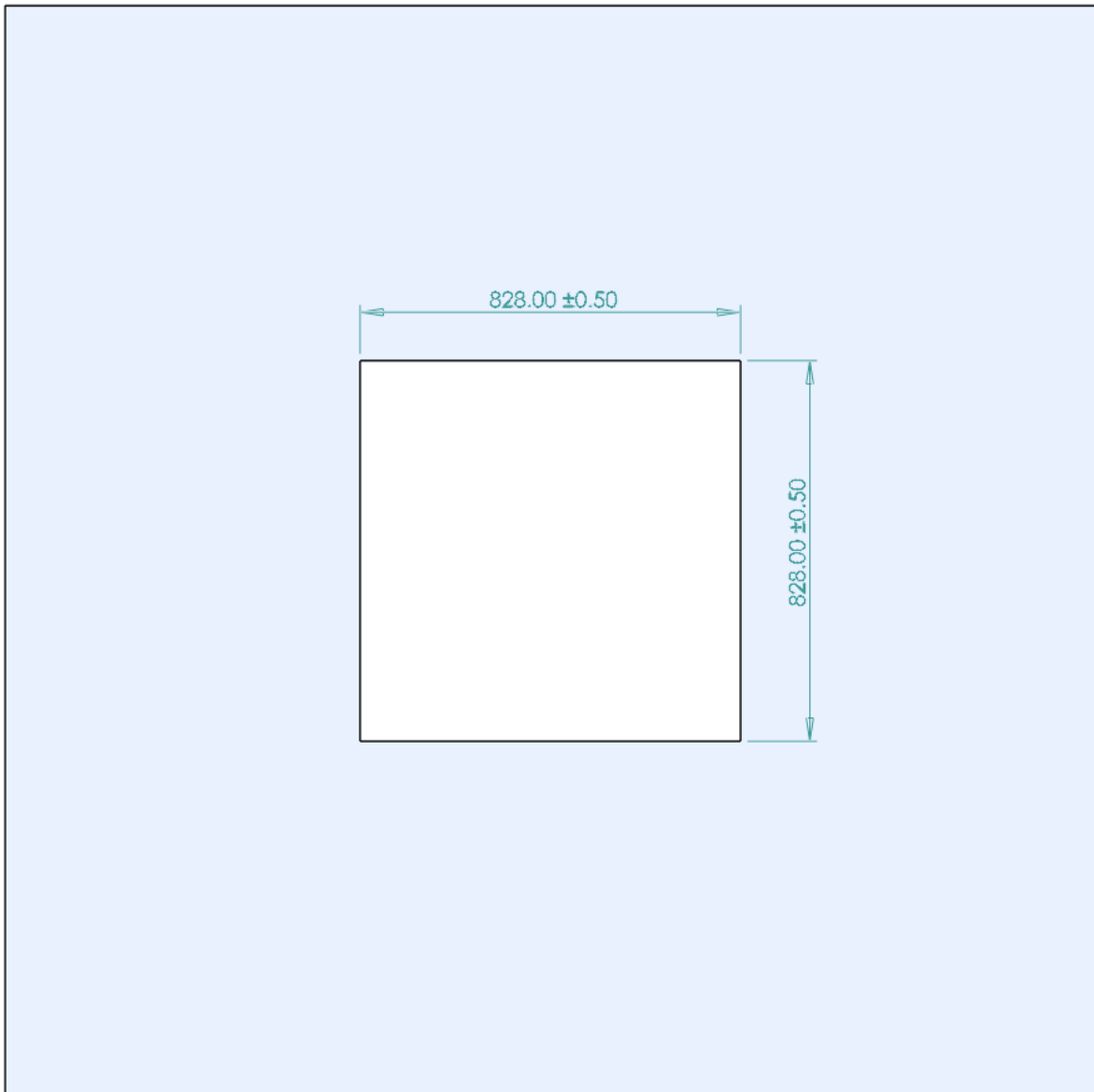

Figure 8 – Dimensions of roof opening.

9.2 Prepare Upstand

1. 18mm Marine plywood upstand to be constructed and fixed by others around the perimeter, with a minimum height of 160mm from the top of the upstand to the roof. This will create an internal opening dimension of 792 x 792mm – see *figure 9*.
2. Maximum overall height of upstand box to be 600mm.
3. Access clearance below upstand for system components to be a minimum of 908mm x 908mm.
4. Ensure upstand has been fully weatherproofed before installation of the heat exchanger.
5. Fix roof overlay ensuring it is secured.
6. Ensure the upstand is plumb and level.

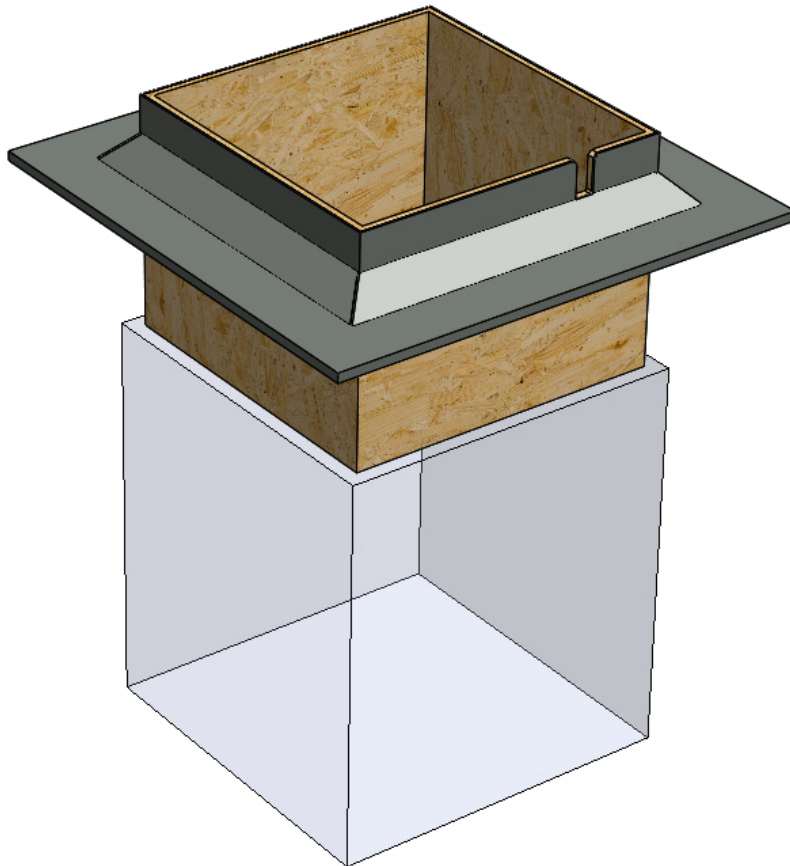

Figure 9 – Upstand dimension details.

9.3 Drain gutter clearance cut-out

1. Mark out shape as per diagram – *see figure 10*.
2. Drill x 2 by 10mm holes as indicated, jigsaw out remainder of shape leaving radiused corners at bottom. Chamfer top corners as shown to aid installation – *see figure 11*.
3. For ducted installations this cut out may need to be in a specific face to enable optimum duct routing, contact Ventive for advice on positioning.

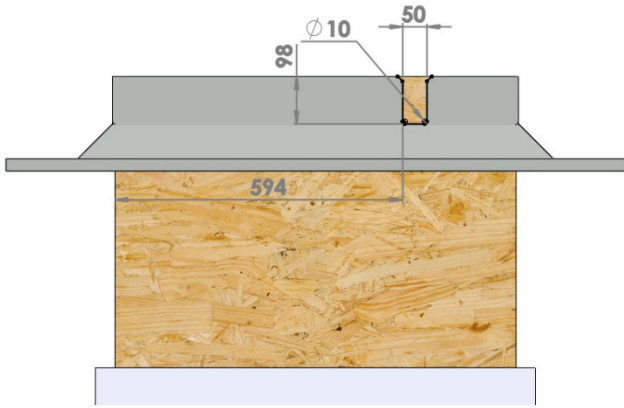

Figure 10 – Upstand cut-out section.

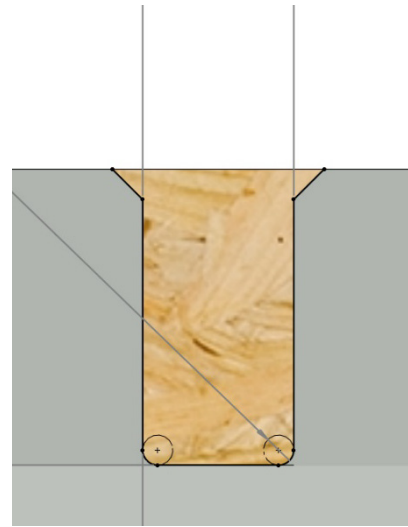

Figure 11 – Upstand drill section.

4. Drain feature in exchanger housing assembly locates into cut out made – *see figure 12*.

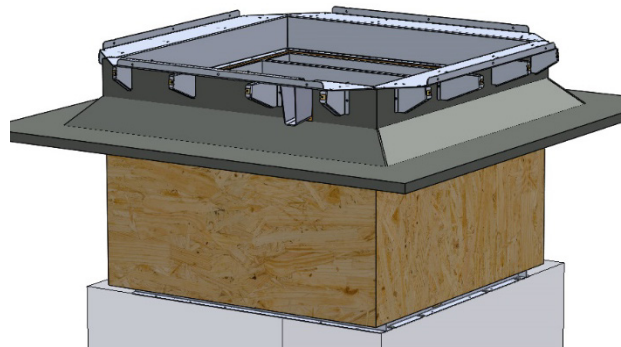

Figure 12 – Exchanger housing drain location assembly.

9.4 Installing the Heat Exchanger

1. Insert the heat exchanger in to the timber aperture – *see figure 13.*
2. Ensure upper perimeter of the heat exchanger sits evenly on the plywood upstand – *see figure 14.*
3. Align screws with the holes in the heat exchanger and fix the heat exchanger frame to the timber upstand. Using the 16 number ST4.2 stainless screws supplied (4 per side in locations as shown in *figure 15.*

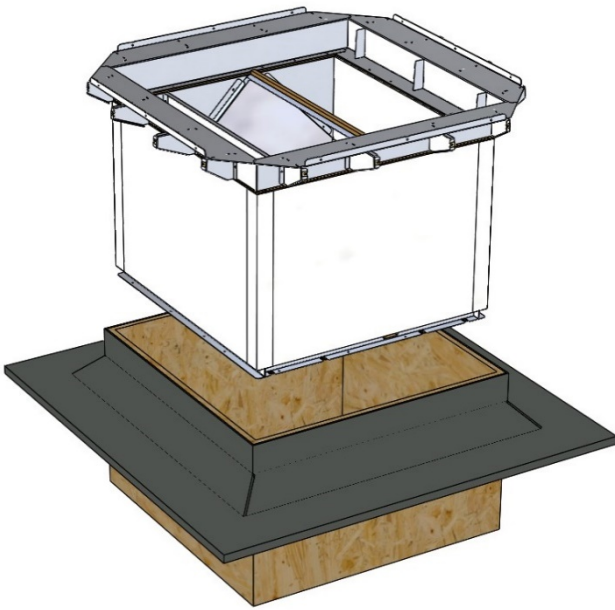

Figure 13 – Heat exchanger position.

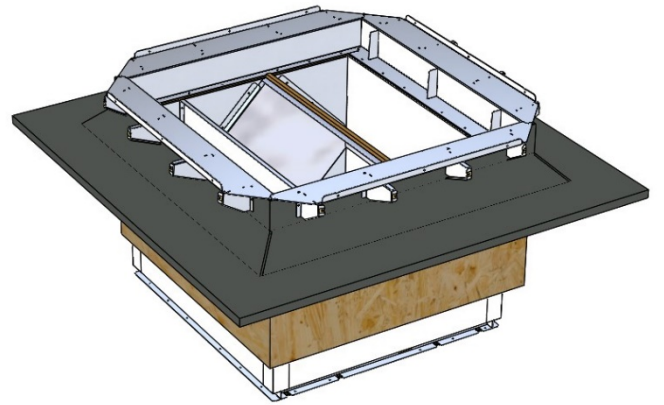

Figure 14 – Heat exchanger final position.

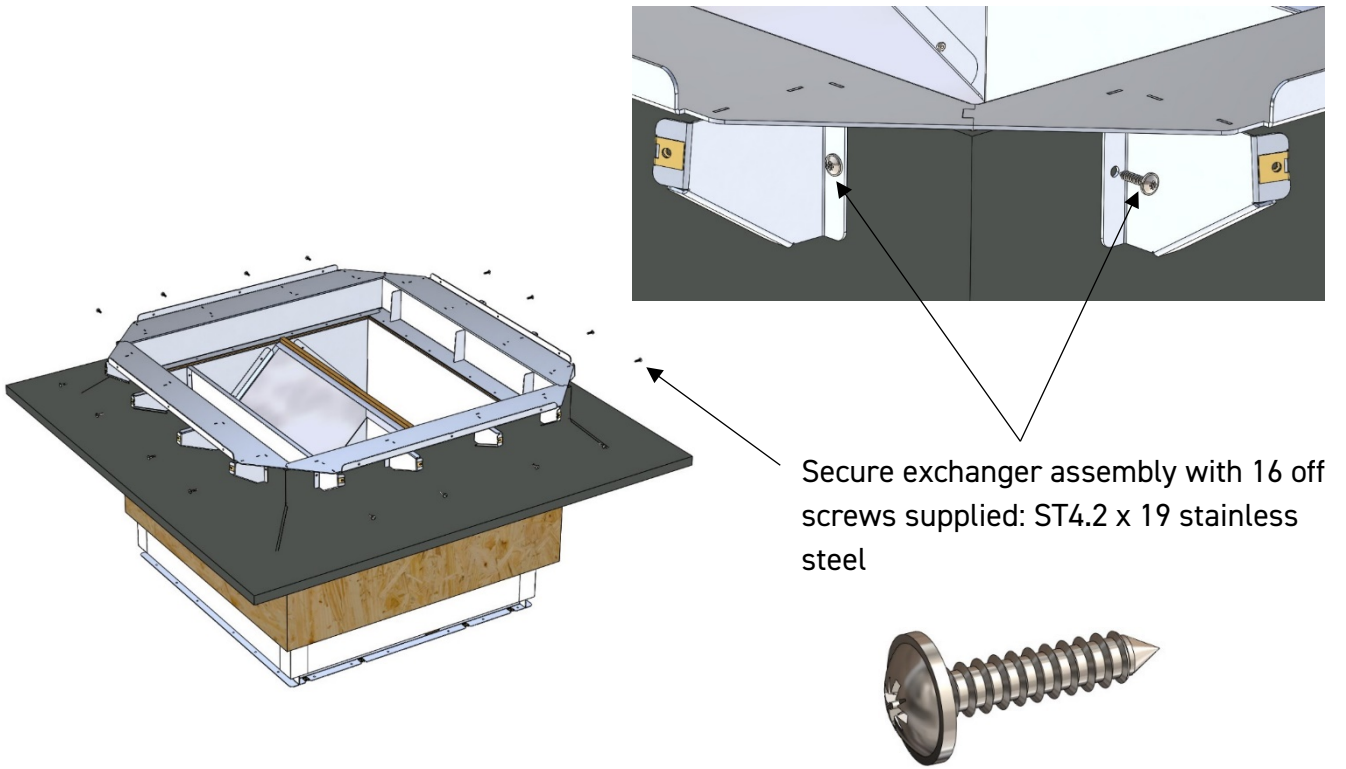

Figure 15 - Screw fixing location for the heat exchanger.

9.5 Fitting the Cowl

1. Ensure the arrows located on the Windhive align with the arrows located on the heat exchanger.
2. Lower the cowl terminal in to place – *see figure 16.*
3. Ensure it sits level on the heat exchanger – *see figure 17.*
4. Secure the casing to the heat exchanger using the 16 number ST4.2 screw supplied fixings in location (4 per side in locations as shown below – *see figure 18.*

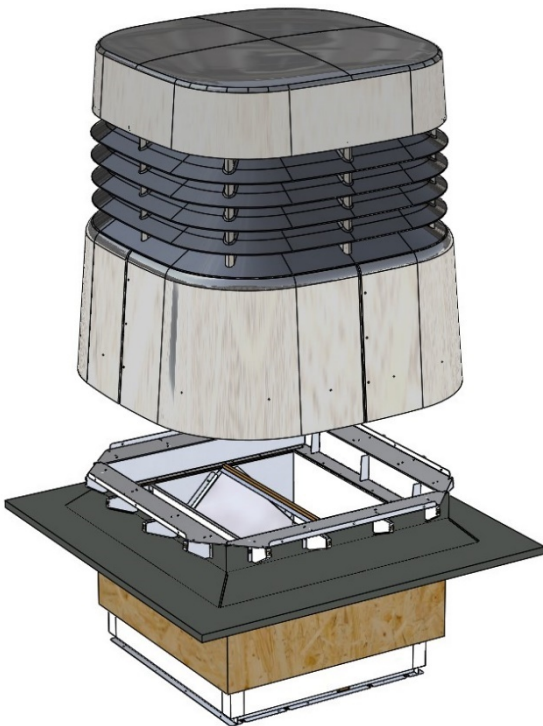

Figure 16 – Cowl position.

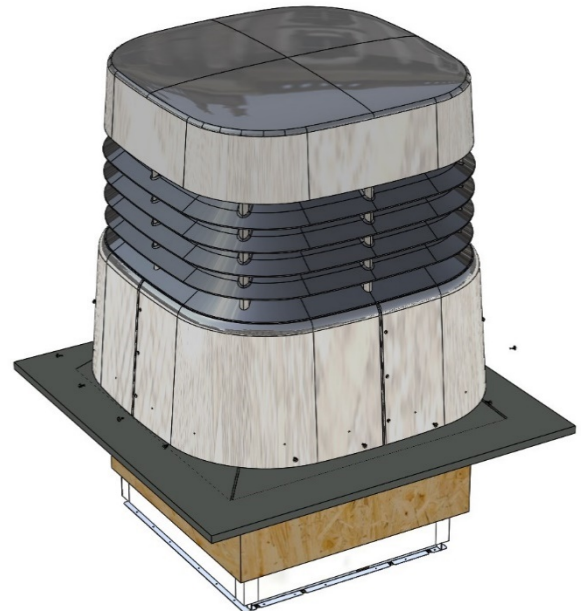

Figure 17 – Final cowl position.



Secure Cowl with 16 off screws supplied:
ST4.2 x 19 stainless steel & stainless/rubber
bonded washers.

Figure 18 - Screw fixing locations for the cowl.

*Note: to continue installation for a pitched roof please go to section 12 Installing the diffuser
internals – All Roof Type page 38.*

10. Flat Roof - Extended Height Applications

10.1 Prepare Roof Opening

1. Create roof opening of minimum 828mm x 828mm (*on the horizontal* - see figure 19).
2. When working with a timber roof construction ensure you use structural opening details or engineer's drawings (joints and trimmers details for clarity).

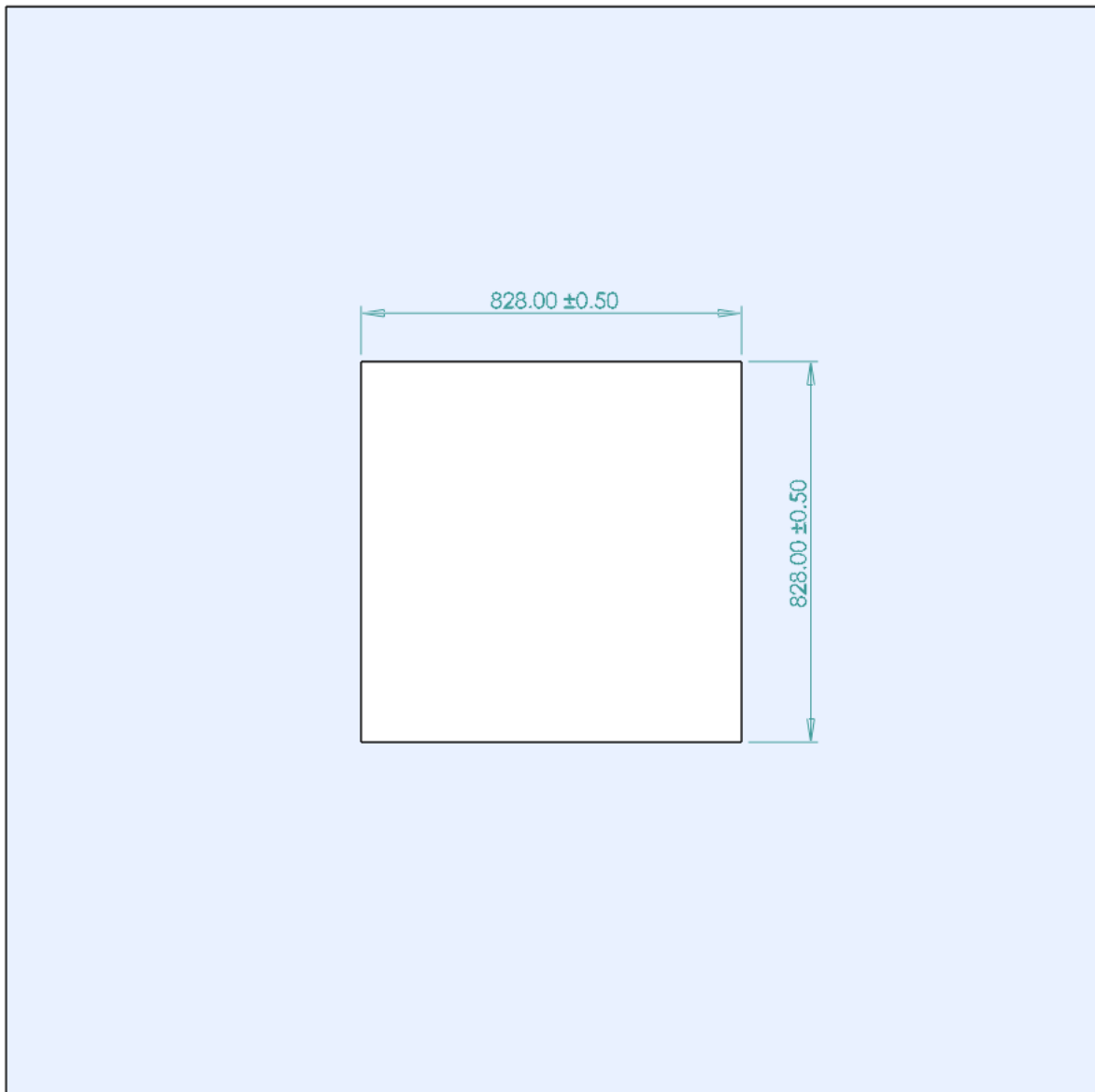

Figure 19 - Dimensions of roof opening.

10.2 Prepare Upstand

1. 18mm Marine plywood upstand to be constructed and fixed by others around the perimeter, with a minimum height of 160mm from the top of the upstand to the roof. This will create an internal opening dimension of 792 x 792mm – see *figure 20*.
2. Maximum overall height of upstand box to be 600mm.
3. Access clearance below upstand for system components to be a minimum of 908mm x 908mm.
4. Ensure upstand has been fully weatherproofed before installation of the heat exchanger.
5. Fix roof overlay ensuring it is secured.
6. Ensure the upstand is plumb and level.

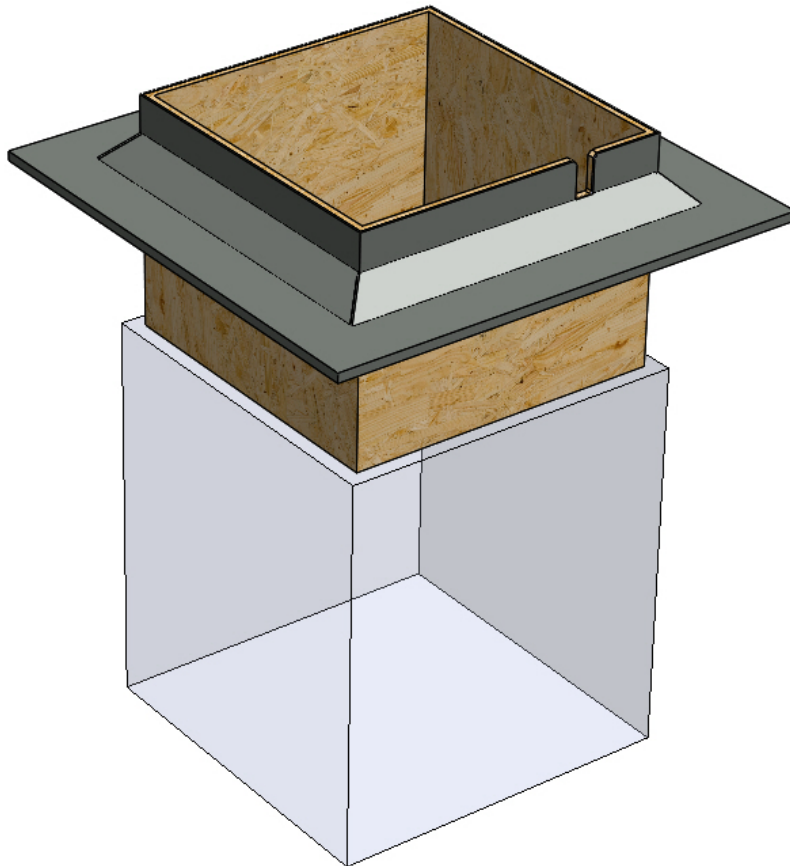

Figure 20 – Upstand dimension details.

10.3 Drain gutter clearance cut-out

1. Mark out shape as per diagram – *see figure 21.*
2. Drill x 2 by 10mm holes as indicated, jigsaw out remainder of shape leaving radiused corners at bottom. Chamfer top corners as shown to aid installation – *see figure 22.*
3. For ducted installations this cut out may need to be in a specific face to enable optimum duct routing, contact Ventive for advice on positioning.

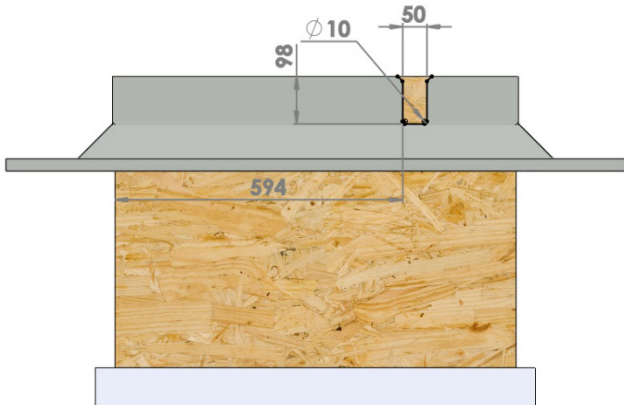

Figure 21 – Upstand cut-out section.

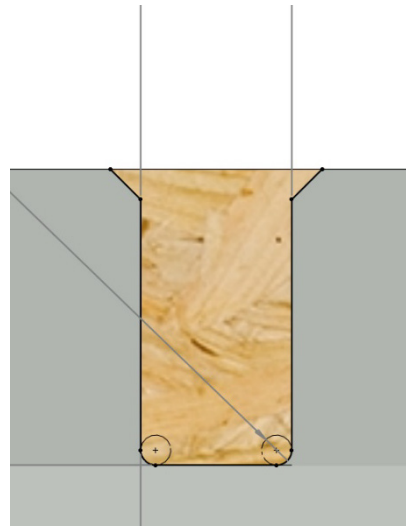

Figure 22 – Upstand drill section.

10.4 Installation of Skirt Extension

1. Lower cowl extension skirt onto roof upstand, ensure the cut out on the skirt aligns with the cut out on the upstand- *see figure 23.*
2. Top rim of skirt should rest on the top edge of roof upstand - *see figures 24 & 25.* Skirt is factory pre-cut to correct depth.

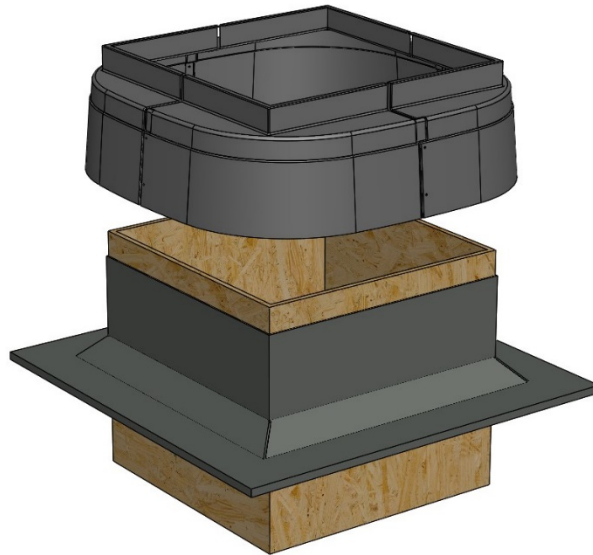
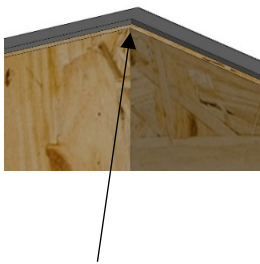

Figure 23 – Skirt extension position.



Top rim of skirt should rest on the top edge of roof upstand.

Figure 24 – Position of rim skirt on top of upstand.

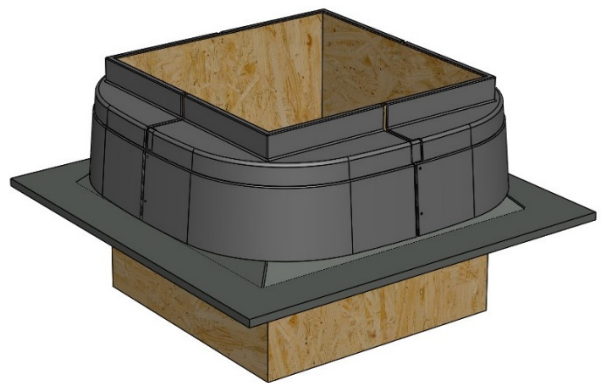

Figure 25 – Skirt extension in final position.

10.5 Installing the Heat Exchanger

1. Insert the heat exchanger in to the timber aperture - *see figure 26.*
2. Ensure upper perimeter of the heat exchanger is level on the top of the plywood upstand - *see figure 27.*
3. Align screws with the holes in the heat exchanger and fix the heat exchanger frame to the timber upstand. Using the 16 number ST4.2 stainless screws supplied (4 per side – *see figure 28.*

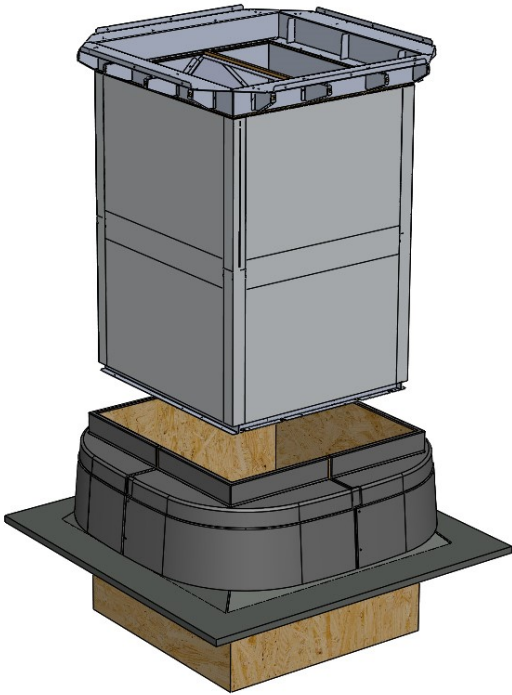

Figure 26 – Heat exchanger position.

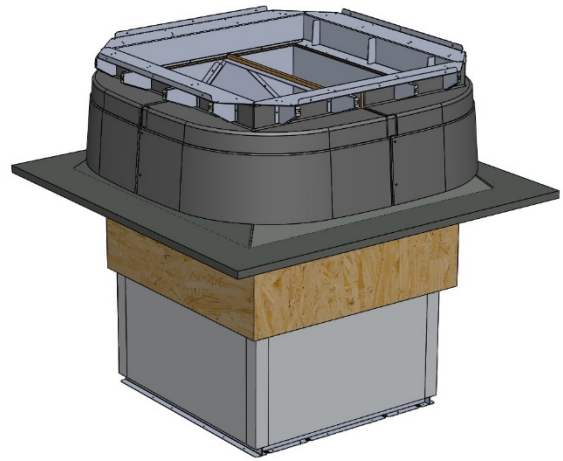
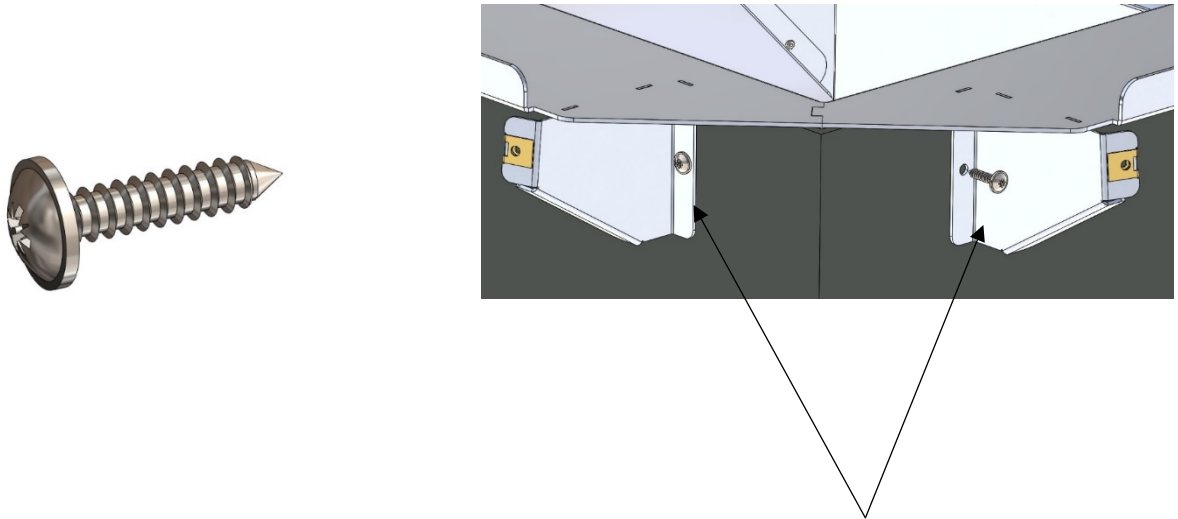

Figure 27 – Heat exchanger final position.



Secure exchanger assembly with 16 off screws supplied: ST4.2 x 19 stainless steel.

Figure 28 – Screw fixing locations for the heat exchanger.

10.6 Fitting the Cowl

1. Ensure the arrows located on the Windhive align with the arrows located on the heat exchanger.
2. Lower the cowl terminal in to place – *see figure 29.*
3. Ensure it sits level on the heat exchanger – *see figure 30.*
4. Secure the casing to the heat exchanger using the 16 number ST4.2 screw supplied fixings in location (4 per side – *see figure 31.*

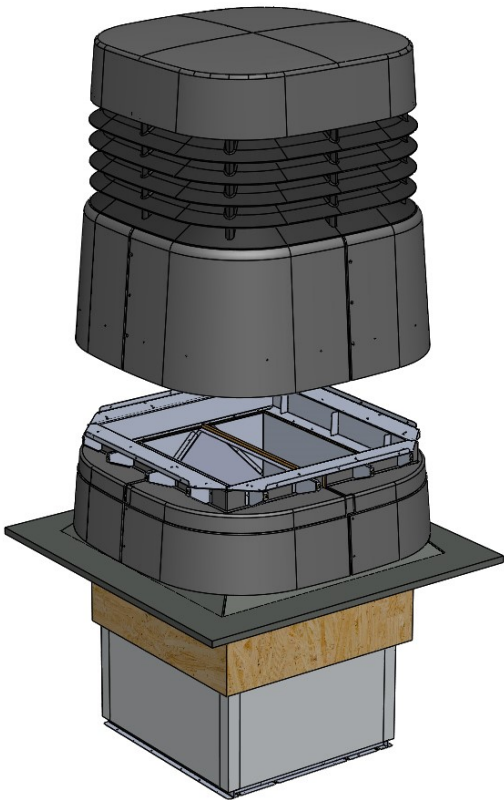

Figure 29 – Cowl position.

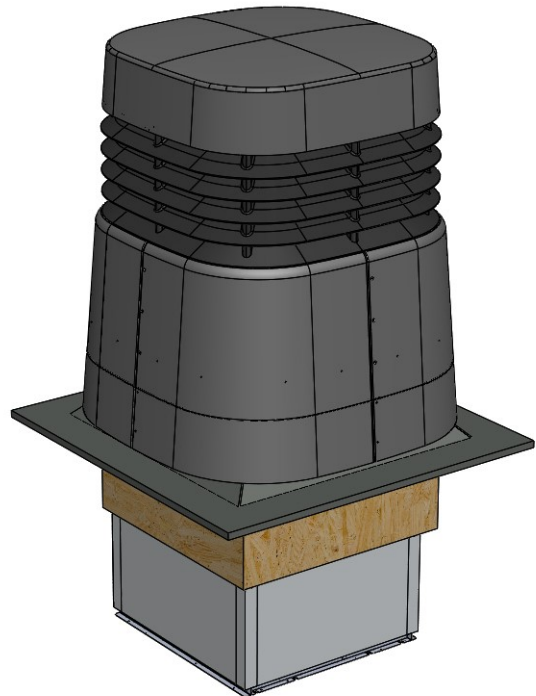
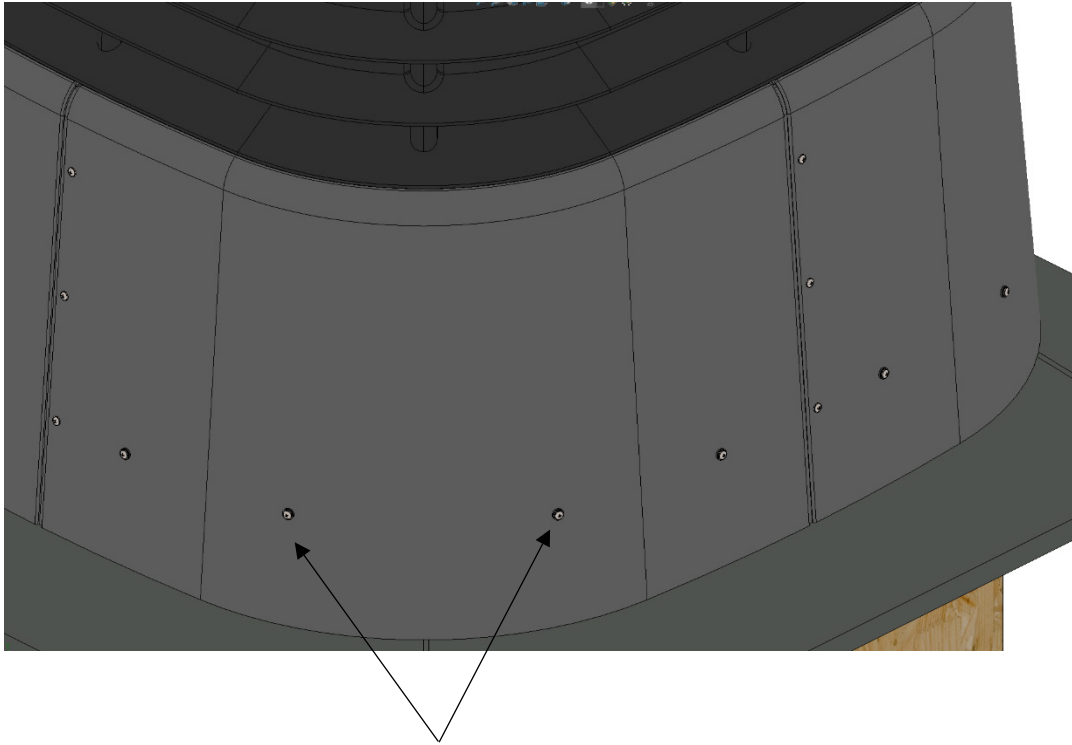

Figure 30 – Final cowl position.



Secure Cowl with 16 off screws supplied: ST4.2 x 19 stainless steel & stainless/rubber bonded washers

Figure 31 – Screw fixing locations for the cowl.

Note: to continue installation for a pitched roof please go to section 12 Installing the diffuser internals – All Roof Type page 38.

11. Pitched Roof Applications

11.1 Prepare Roof Opening

1. Create roof opening of minimum 828mm x 828mm (*on the horizontal* - see figure 32).
2. When working with a timber roof construction ensure you use structural opening details or engineer's drawings (joints and trimmers details for clarity).

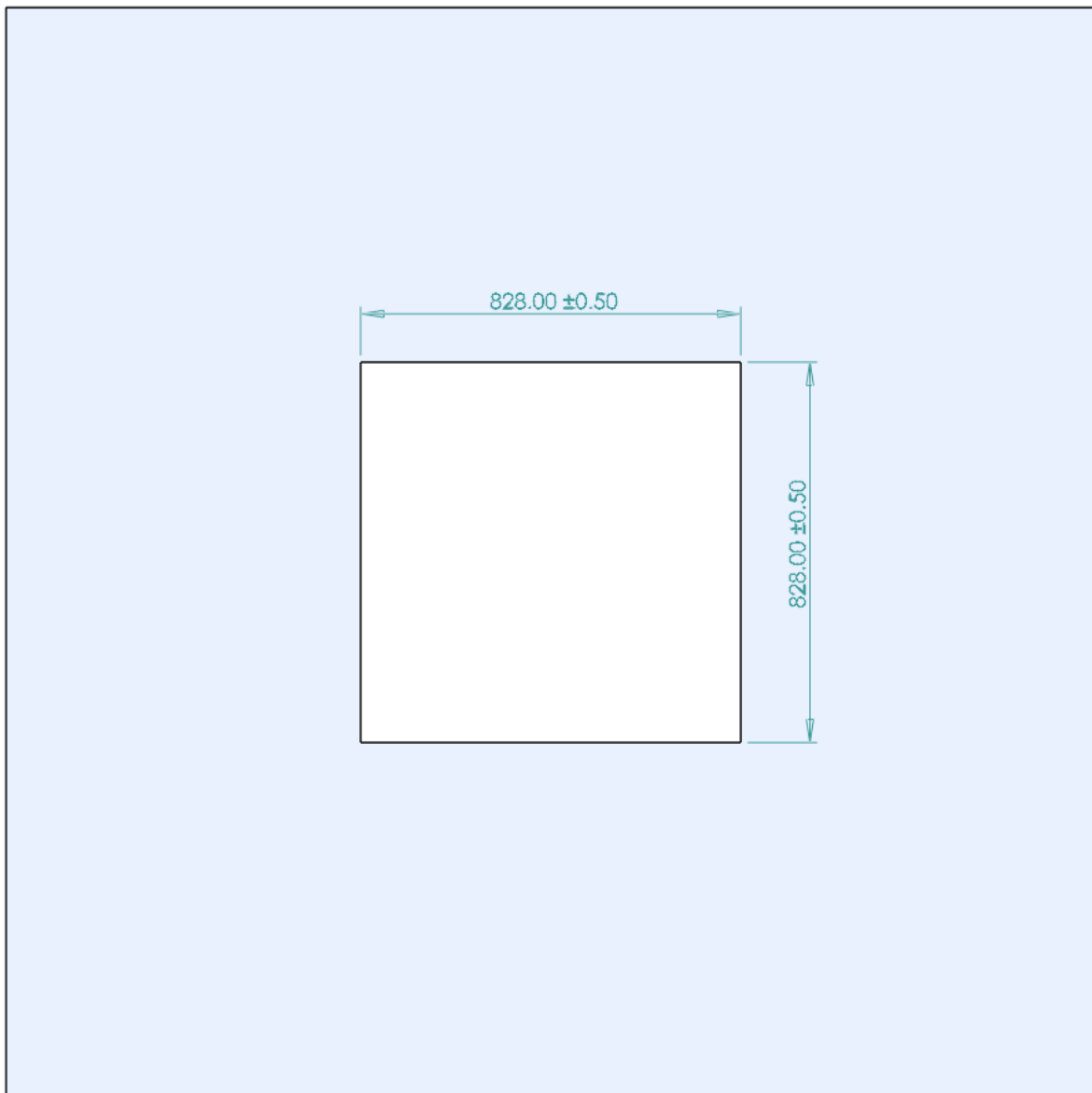

Figure 32 – Dimensions of roof opening.

11.2 Prepare Upstand

1. 18mm marine plywood upstand to be constructed and fixed by others around the perimeter, for minimum height details please refer to roof pitch configurations below.

For roofs with 9°– 20° pitch

- Minimum height of upstand above finished roof surface to be 170mm.
- Maximum overall height of upstand box to be 850mm.

For roofs with 31°– 40° pitch

- Minimum height of upstand above finished roof surface to be 180 - 200mm.
- Maximum overall height of upstand box to be 1387mm.

For roofs with 21°– 30° pitch

- Minimum height of upstand above finished roof surface to be 160 - 180mm.
- Maximum overall height of upstand box to be 1137mm.

2. This will create an internal opening dimension of 792 x 792mm – *see figure 33.*
3. Access clearance below upstand for system components to be a minimum of 908mm x 908mm.
4. Ensure upstand has been fully weatherproofed before installation of the heat exchanger.
5. Fix roof overlay ensuring it is secured.
6. Ensure the upstand is plumb and level.

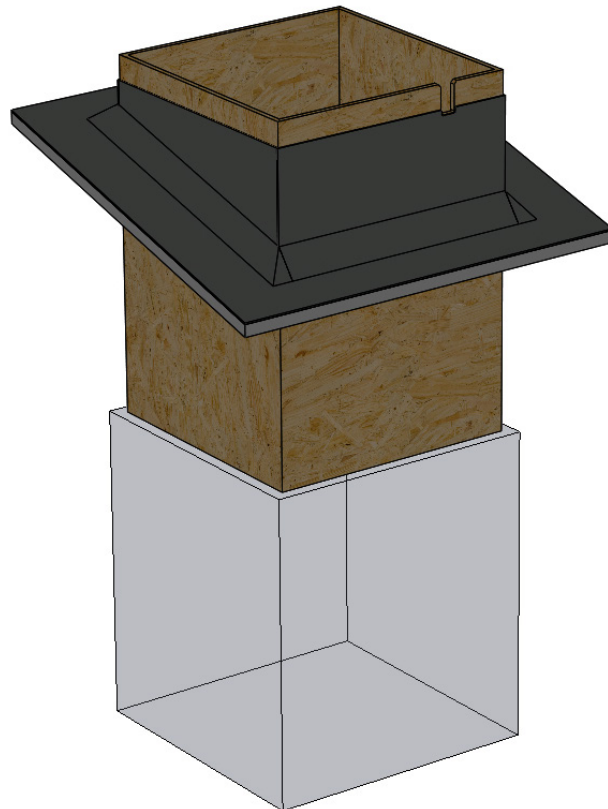

Figure 33 – Upstand dimension details.

11.3 Drain gutter clearance cut-out

1. Mark out shape as per diagram – *see figure 34.*
2. Drill x 2 by 10mm holes as indicated, jigsaw out remainder of shape leaving radiused corners at bottom. Chamfer top corners as shown to aid installation – *see figure 35.*
3. For ducted installations this cut out may need to be in a specific face to enable optimum duct routing, contact Ventive for advice on positioning.

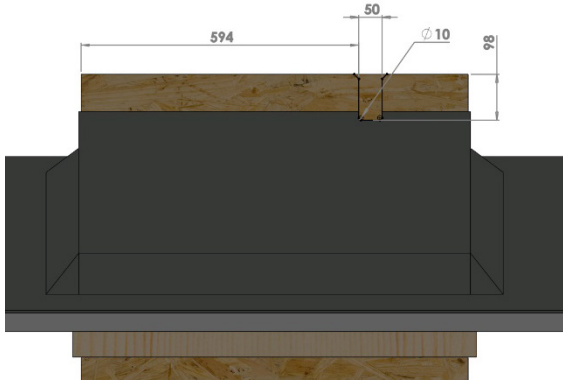

Figure 34 – Heat exchanger position.

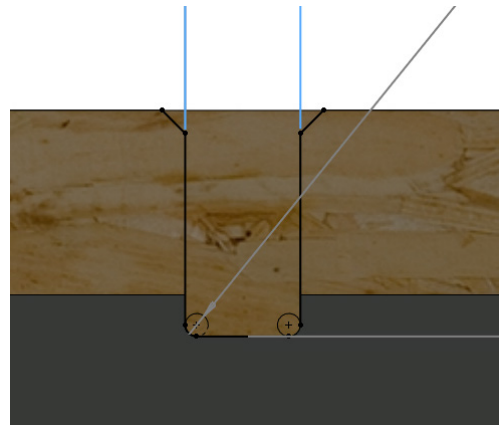

Figure 35 – Heat exchanger final position.

11.4 Installation of Skirt Extension

1. Lower cowl extension skirt onto roof upstand, ensure the cut out on the skirt aligns with the cut out on the upstand - *see figure 36.*
2. Top rim of skirt should rest on the top edge of roof upstand - *see figure 37.* Skirt is factory pre-cut to required angle & depth.

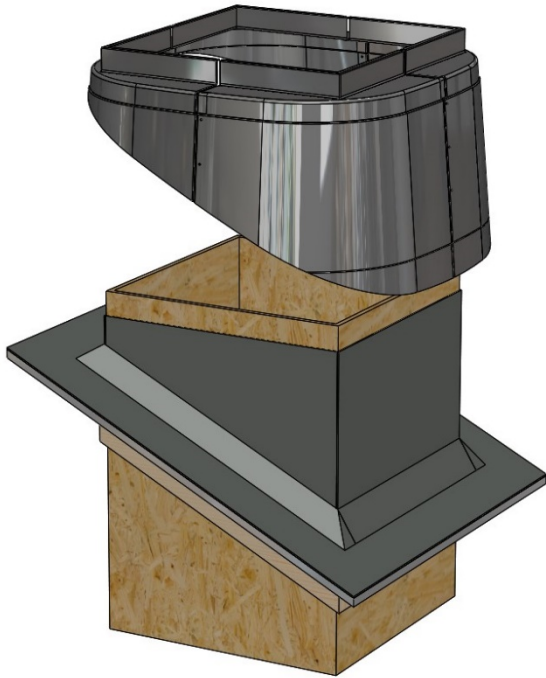

Figure 36 – Skirt extension orientation.

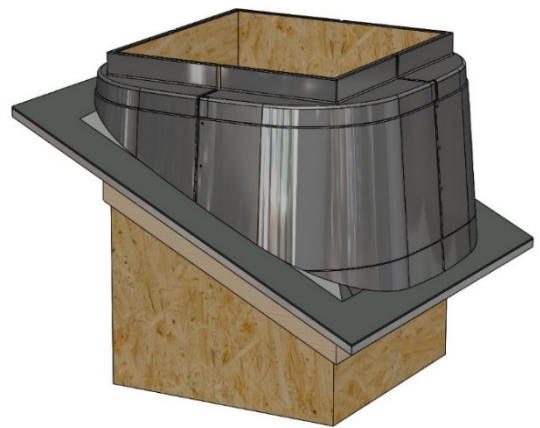

Figure 37 – Skirt extension final position.

11.5 Extensions Pieces

Extension pieces are required for roofs with a pitch of 9° and higher, the extensions are preassembled to the bottom of the heat exchanger. For information on the extension pieces provided please refer to roof pitch configuration below.

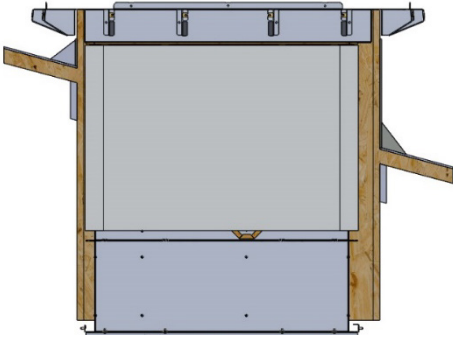

Figure 38 – Windhive with 250mm extension.

Roofs with a 9° - 20° pitch

Require a 250mm – this is preassembled to the bottom of the heat exchanger

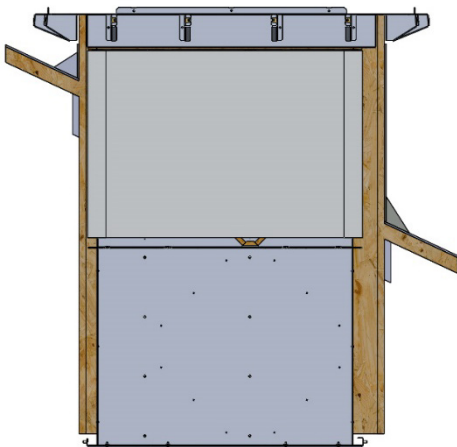

Figure 39 – Windhive with 500mm extension.

Roofs with a 21° - 30° pitch

Require a 500mm – this is preassembled to the bottom of the heat exchanger

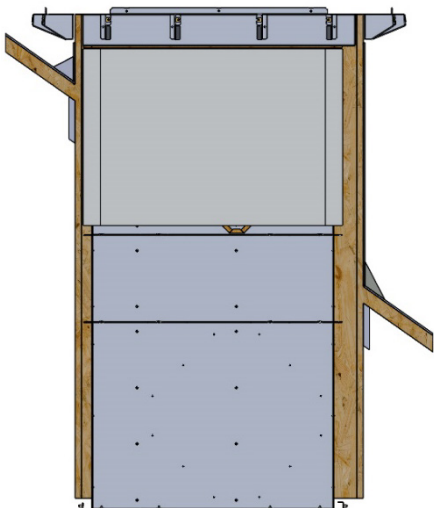

Figure 40 – Windhive with 250mm & 500mm extension.

Roofs with a 31° - 40° pitch

Require a 250mm & 500mm extension – both extension pieces are preassembled together and riveted to the bottom of the heat exchanger

11.6 Installing the heat exchanger

1. Insert the heat exchanger in to the timber aperture - *see figure 41.*
2. Ensure upper perimeter of the heat exchanger is level on the top of the plywood upstand - *see figure 42.*
3. Align screws with the holes in the heat exchanger and fix the heat exchanger frame to the timber upstand. Using the 16 number ST4.2 stainless screws supplied (4 per side - *see figure 43.*

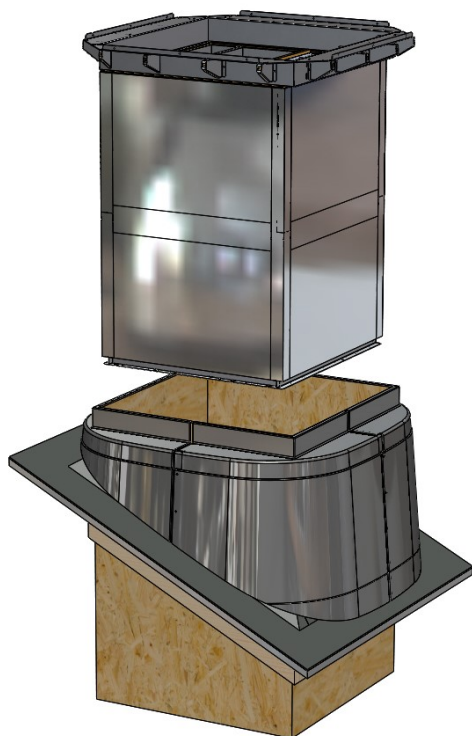

Figure 41 – Heat exchanger orientation.

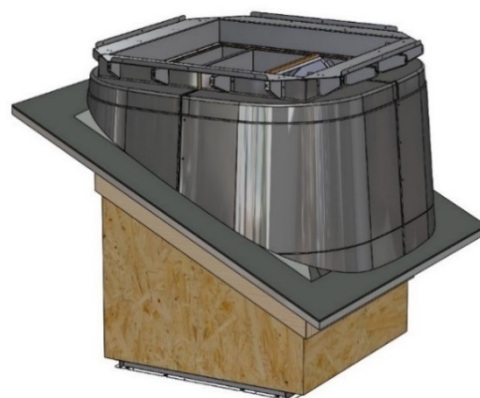

Figure 42 – Heat exchanger final position.

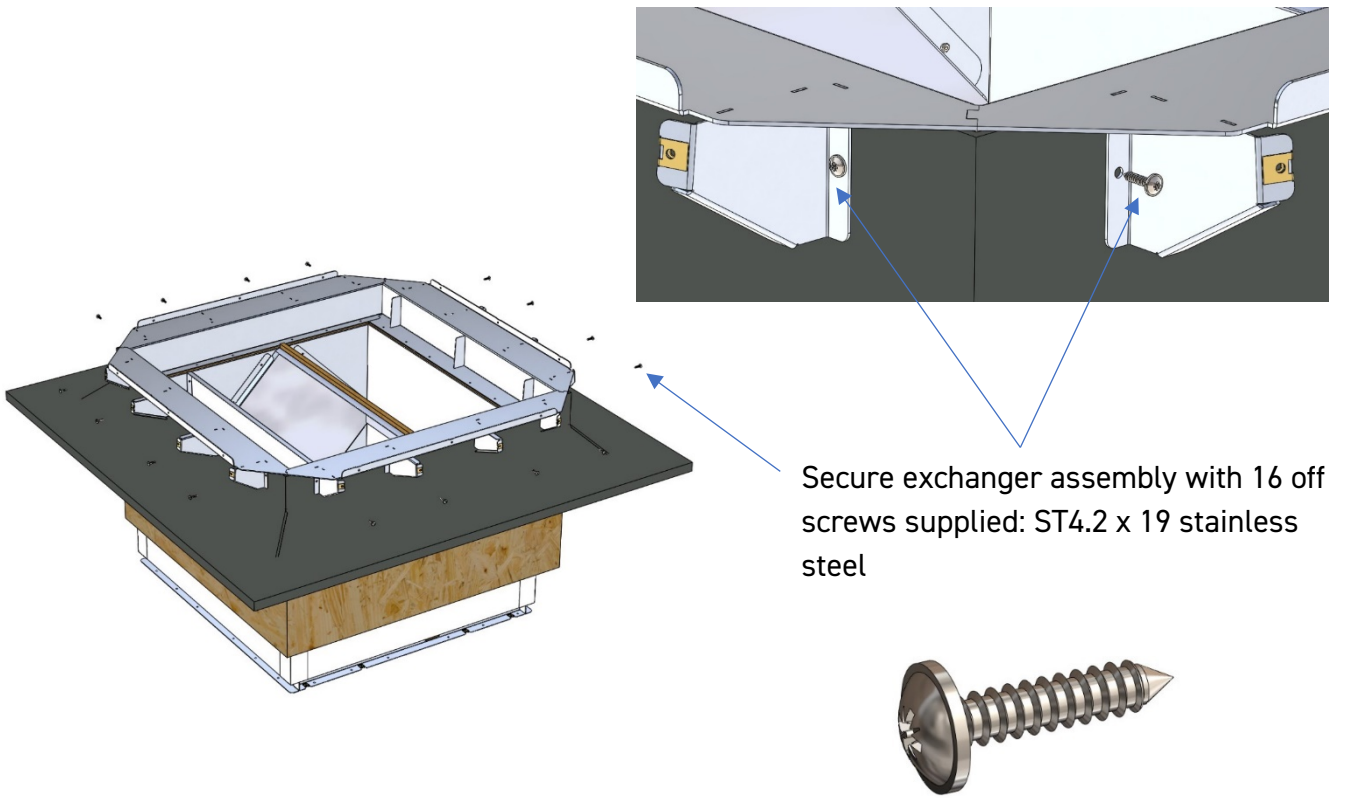

Figure 43 - Screw fixing locations for the heat exchanger.

11.7 Fitting the Cowl

1. Ensure the arrows located on the Windhive align with the arrows located on the heat exchanger.
2. Lower the cowl terminal in to place - *see figure 44*.
3. Ensure it sits level on the heat exchanger - *see figure 45*.
4. Secure the casing to the heat exchanger using the 16 number ST4.2 screw supplied fixings in location (4 per side - *see figure 46*).

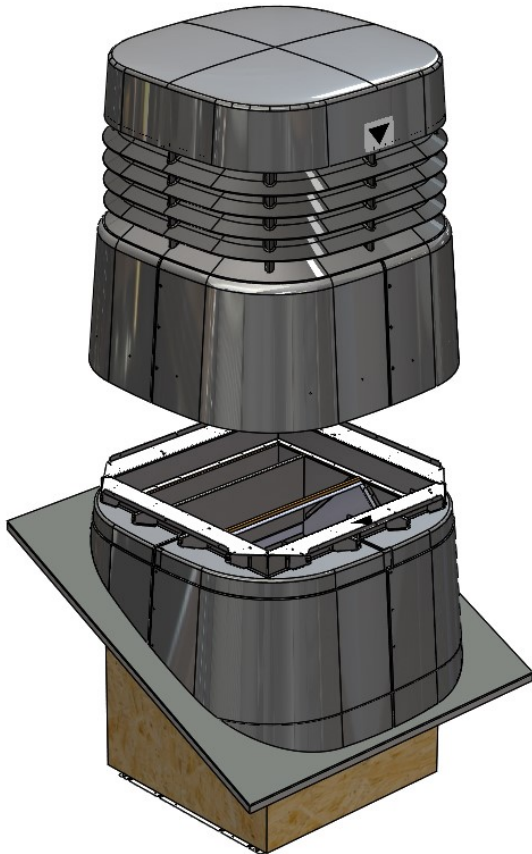

Figure 44 – Cowl orientation.

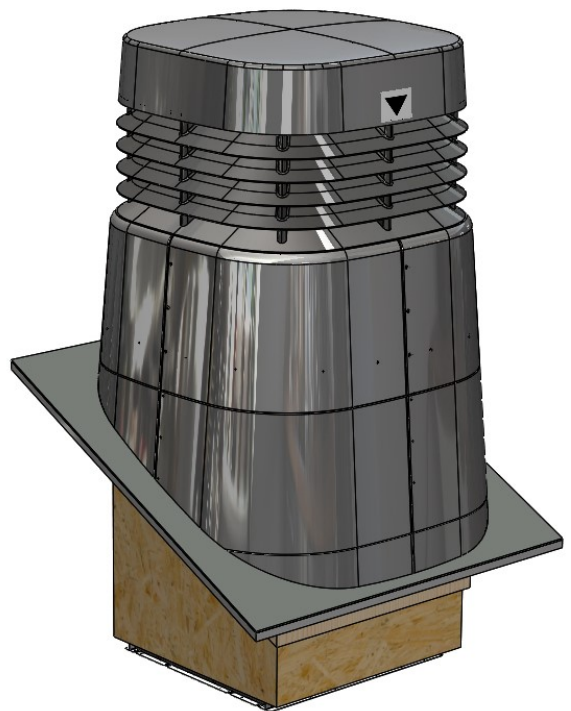
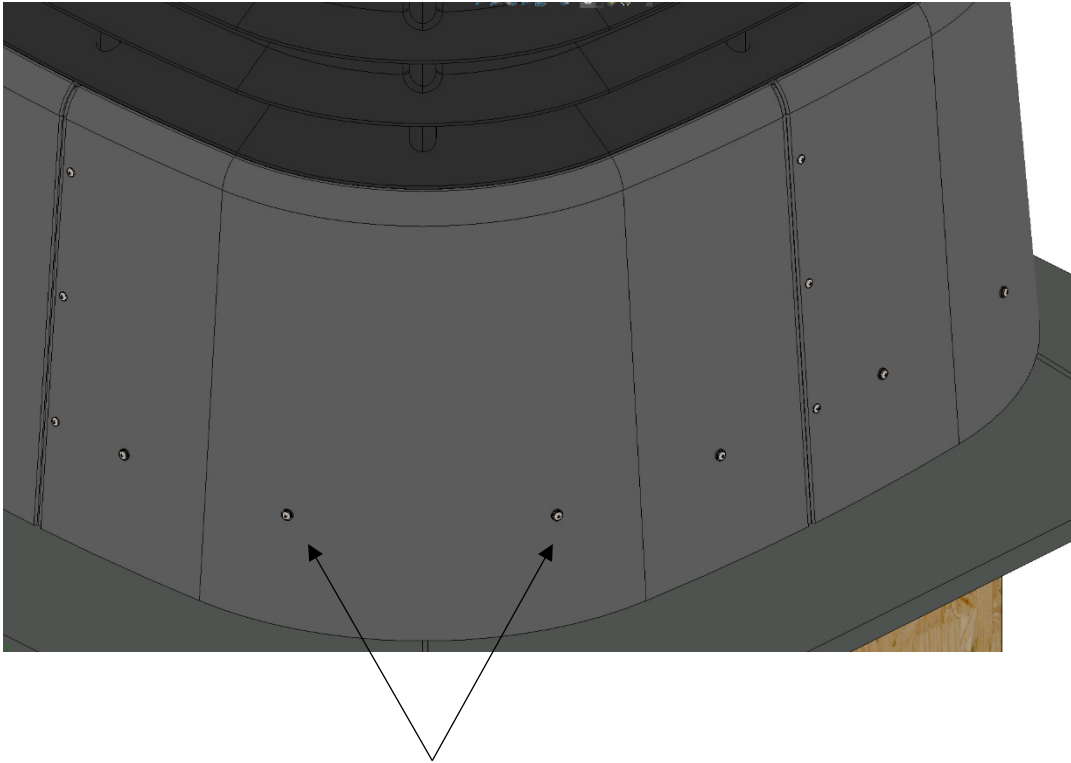

Figure 45 – Final cowl position.



Secure Cowl with 16 off screws supplied: ST4.2 x 19 stainless steel & stainless/rubber bonded washers

Figure 46 – Screw fixing location for the cowl.

Note: to continue installation for a pitched roof please go to section 12 Installing the diffuser internals – All Roof Type page 38.

12. Installing the Internal Diffuser

Note: Please start this section once you have completed either section 9, 10, or 11.

12.1 Internal Diffuser Installation

1. Hook the internal diffuser on to one side of the heat exchanger housing (flat roof application or extension piece (extended height/pitched roof application) ensuring the arrows are aligned – see figure 47 and 48.
2. Then secure into place using the pre-fitted screws – see figure 49 and 50.

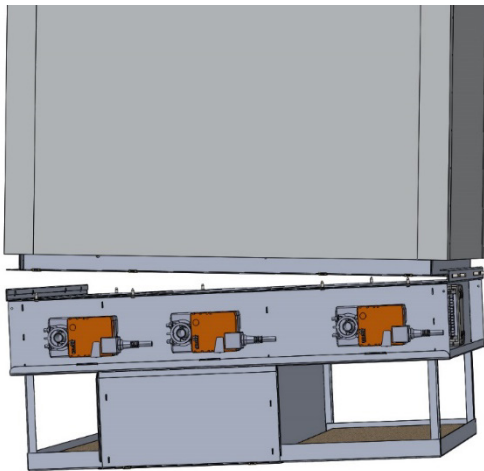

Figure 47 – Internal diffuser orientation.

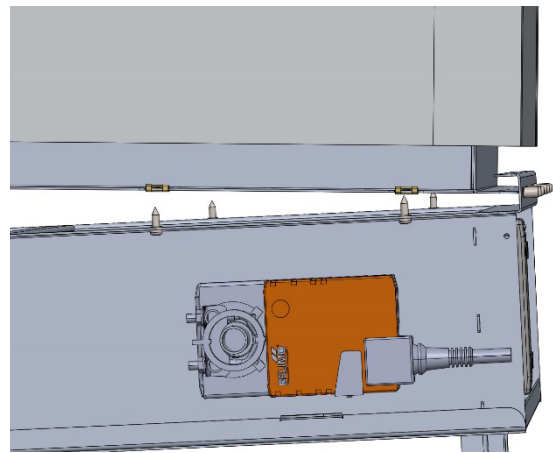

Figure 48 – Internal diffuser orientation.

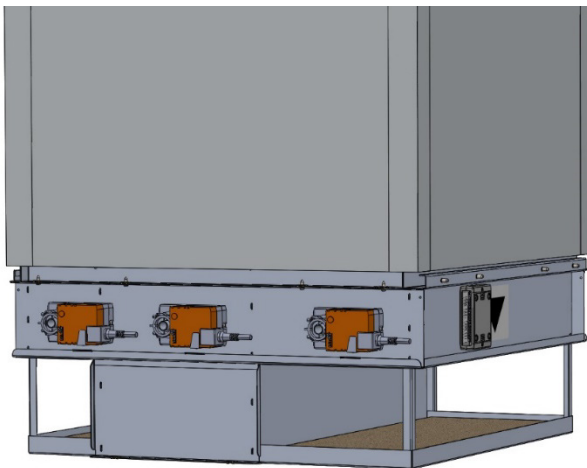

Figure 49 – Internal diffuser position.

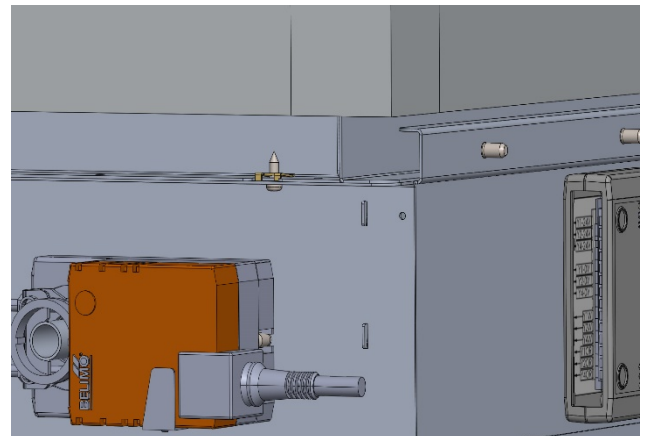

Figure 50 – Internal diffuser position

3. Ensure the arrows on the diffuser and heat exchanger align. The diffuser can only be installed in one orientation.
4. Secure diffuser into place with the 8 pre-fitted screws on each long side of diffuser – see figures 51 & 52.

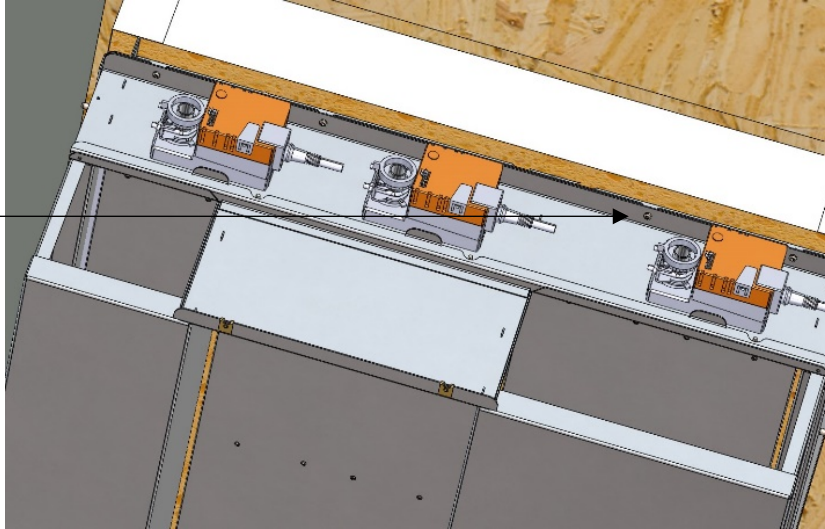

Figure 51 – Screw fixing locations for the internal diffuser.

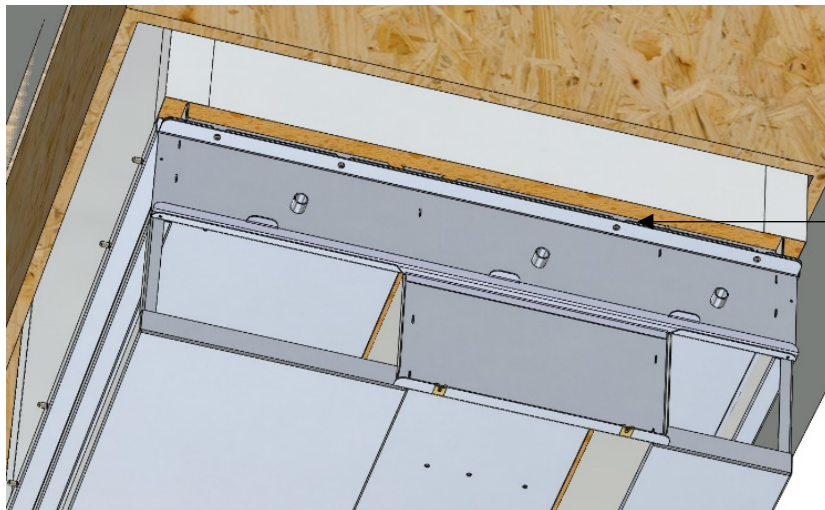

Figure 52 – Screw fixing locations for the internal diffuser.

5. You will need to connect the 3 internal actuators to a 24V DC power supply – see figure 53.

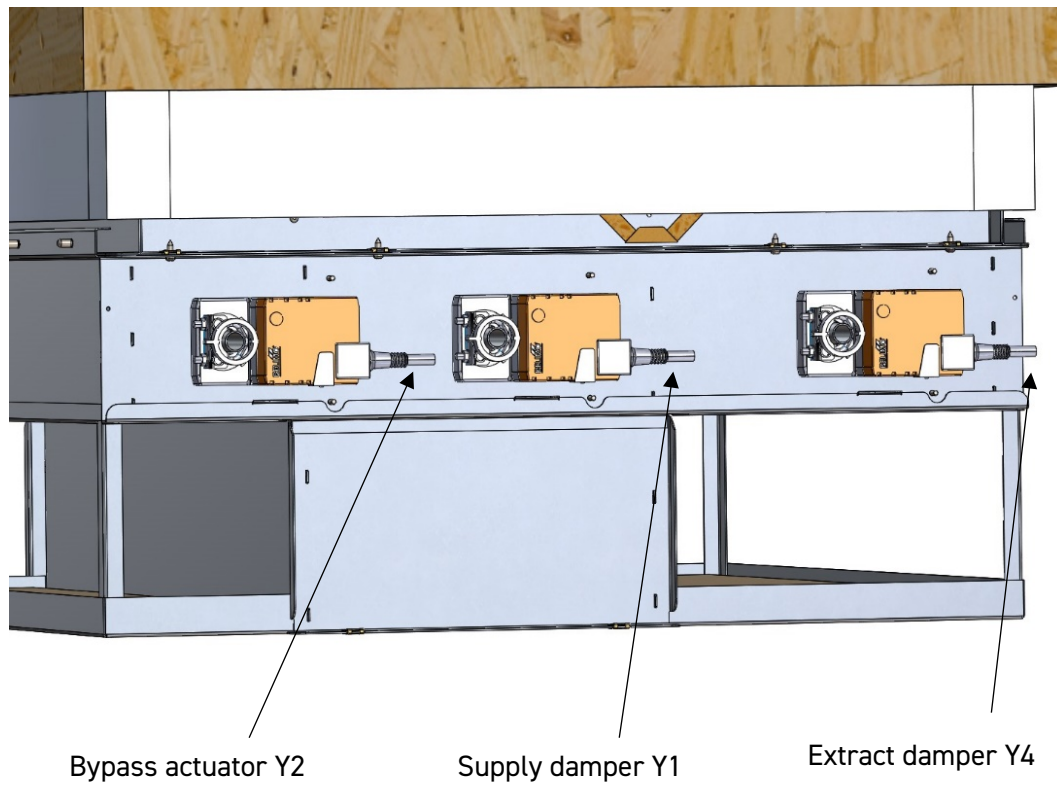

Figure 53 – Actuator locations.

12.2 Installing Absorption Bag

1. Once the external diffuser box has been fitted, remove the outer plastic bag from the absorption bags and place one absorption bag in each compartment – see *figure 54*.

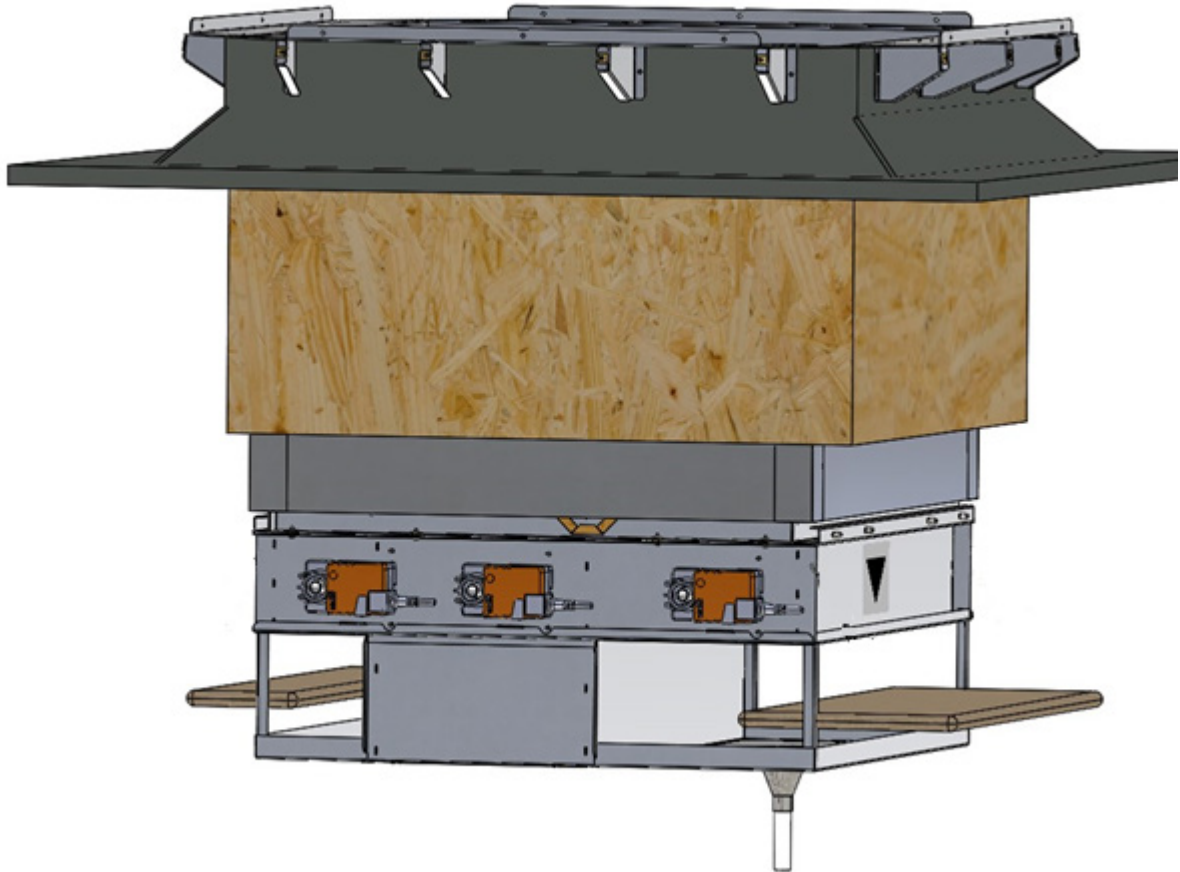

Figure 54 - Absorption Bags

13. Installing Ceiling Mounted Diffuser Box

Note: Please start this section if you are installing a ceiling mounted in room system.

13.1 External Diffuser Box

1. The External Diffuser Box assembly has been designed to fit over the Internal Diffuser Assembly for below ceiling configurations – *see figure 55.*

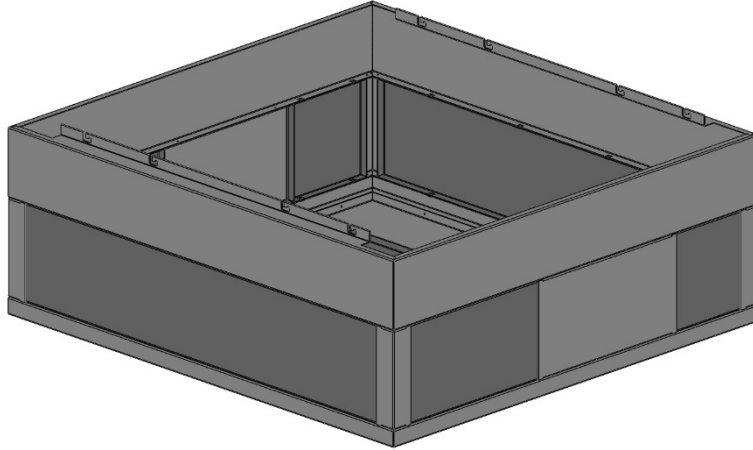

Figure 55 – External Diffuser Box

13.2 Fitting the External Diffuser Box

1. Offer the External Assembly over the Internal Assembly ensuring that it is in the correct orientation by aligning the arrows on both parts – *see figure 56.*

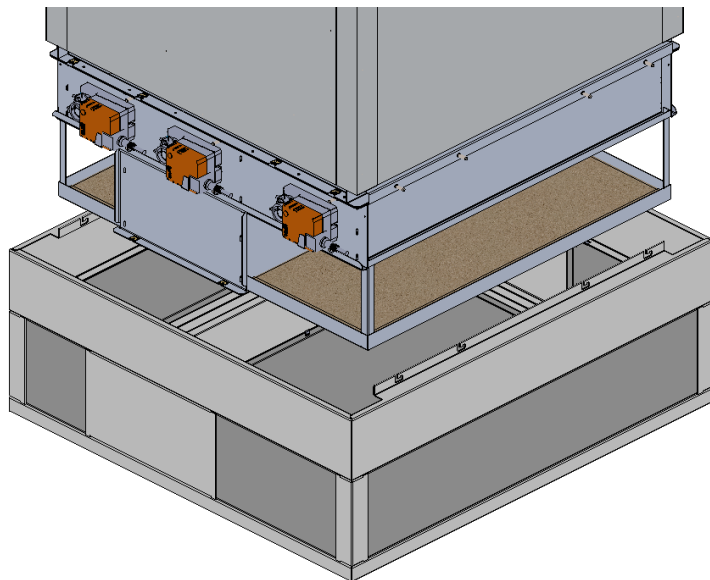

Figure 56 – Diffuser box position.

2. Locate the pins with the grooves on both sides of the assemblies. All 8 pins should be located – see figure 57.

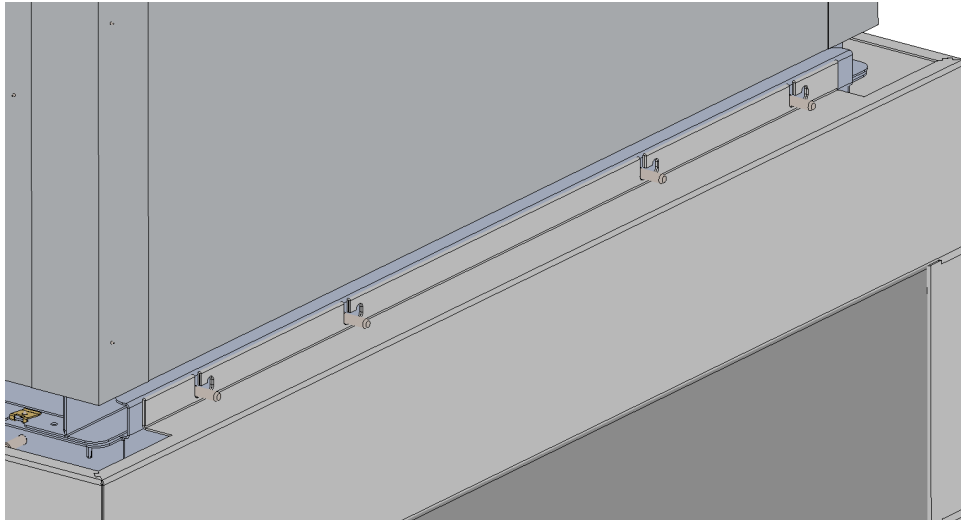

Figure 57 – Diffuser box pin location.

3. Slide the External Diffuser forward until all 8 pins sit within the notch, locking it in place – see figure 58.

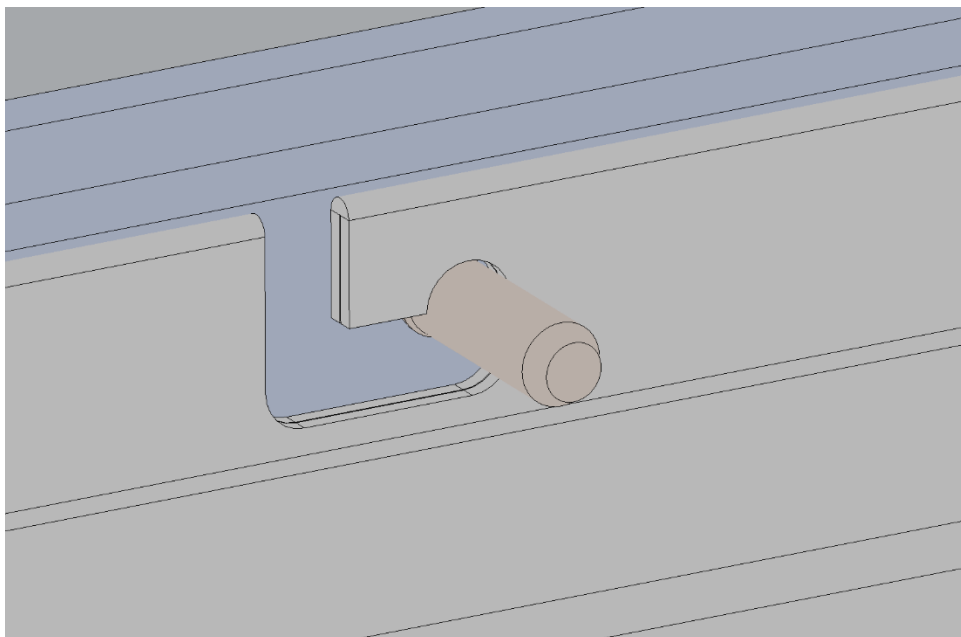

Figure 58 – Diffuser box pin location.

13.3 Fully Assembled External Diffuser

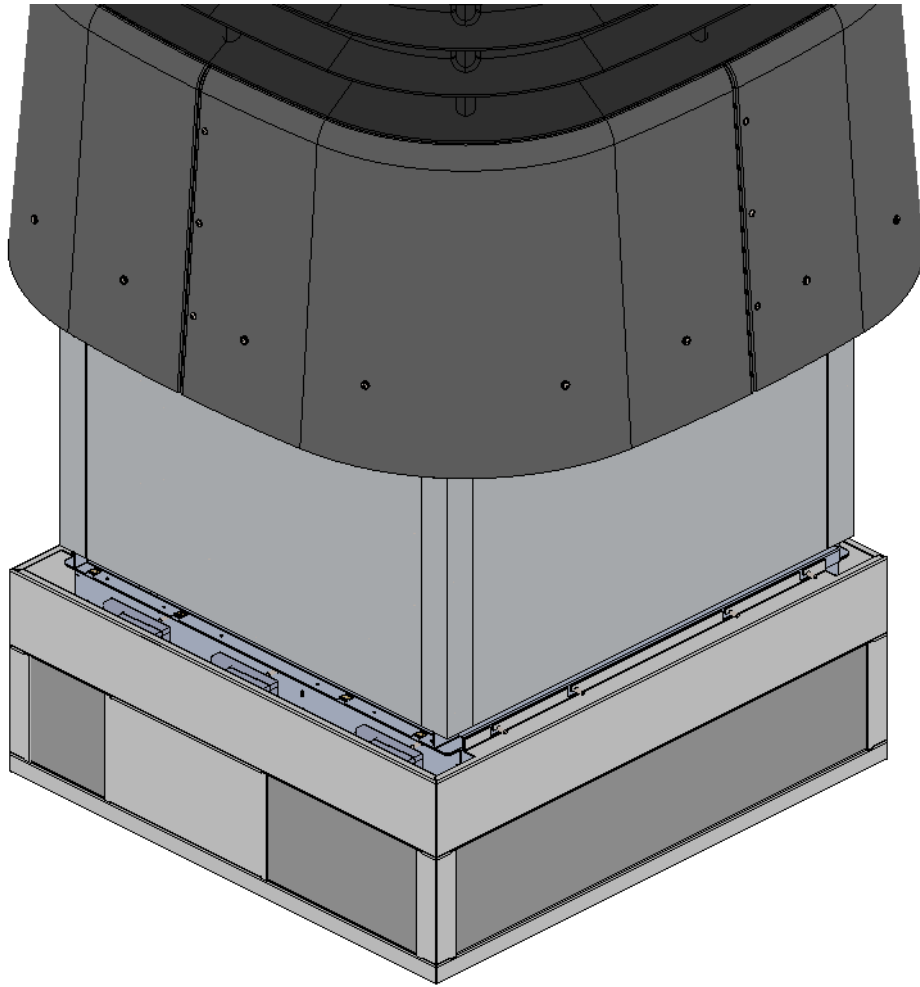

Figure 59 - Fully Assembled External Diffuser.

14. Installing the Plenum Box for Ducted System

Note: Please start this section if you are installing a ducted system.

14.1 Fitting the plenum box assembly.

1. Attach supply duct adaptor to diffuser supply duct as shown using the double sided foam tape factory attached to the adaptor – *see figure 60.*
2. Secure fully in place with the 4 pre-fitted self tapping screws at each end of the adaptor – *see figure 61.*

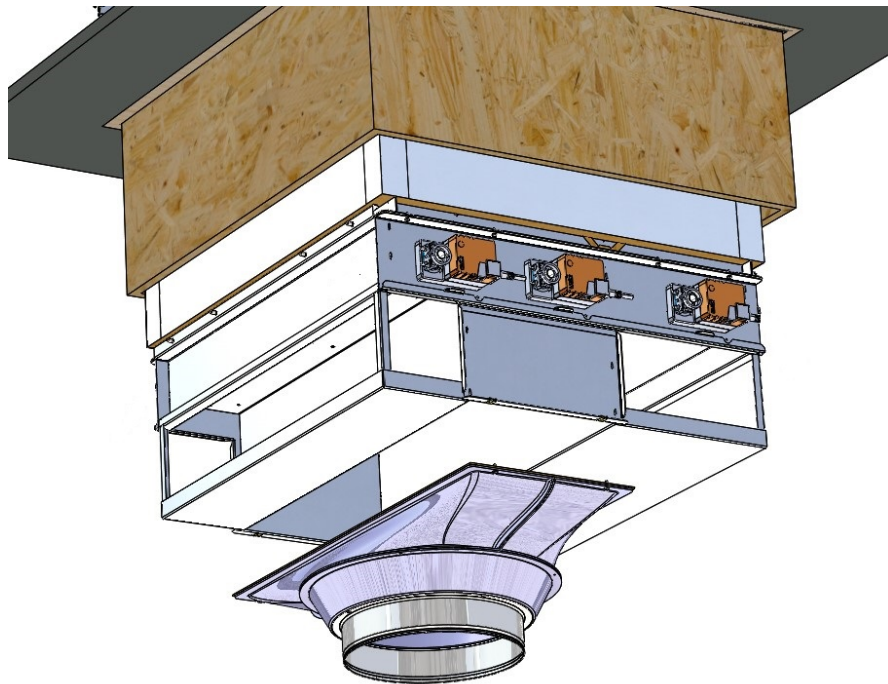
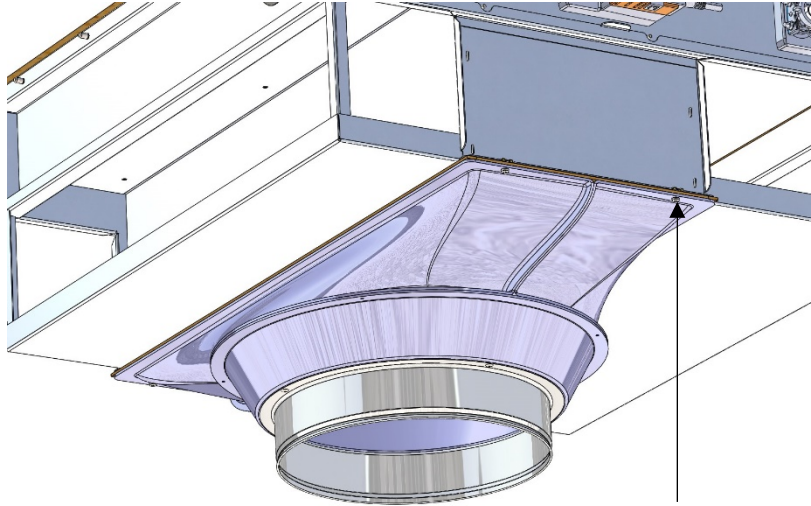

Figure 60 – Plenum box position.



Secure fully in place with the 4 pre-fitted self-tapping screws

Figure 61 – Plenum box position.

15. Ducting Details

15.1 Ducting Installation

1. When using flexible ducting ensure that it is appropriately supported and protected;
2. It is recommended that all duct runs are as vertical as possible to ensure good ventilation performance;
3. Use of 90° bends is not advised (unless on final connection).
4. All joints should be mechanically fixed (using screws or duct clips and then taped to create a sealed connection);
5. The supply inlet should be placed as low as practically possible.
6. Each extract to be mounted in the highest possible point of each ventilated area (200mm maximum recommended distance below the ceiling);
7. Please ensure that both inlet and outlet are unobstructed and located in areas unlikely to be obstructed in the future.

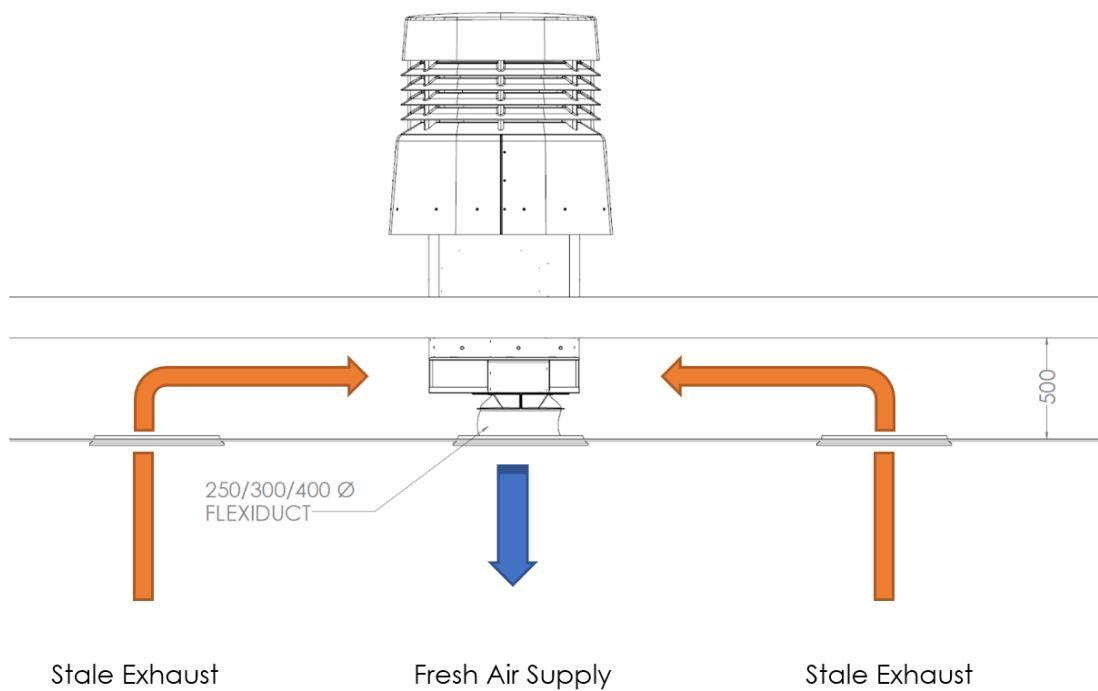

Figure 62 – Detailed ducted drawing.

15.2 Duct Variants

The Ventive Windhive has three different spigot variations depending on the size you need for your project.

400mm

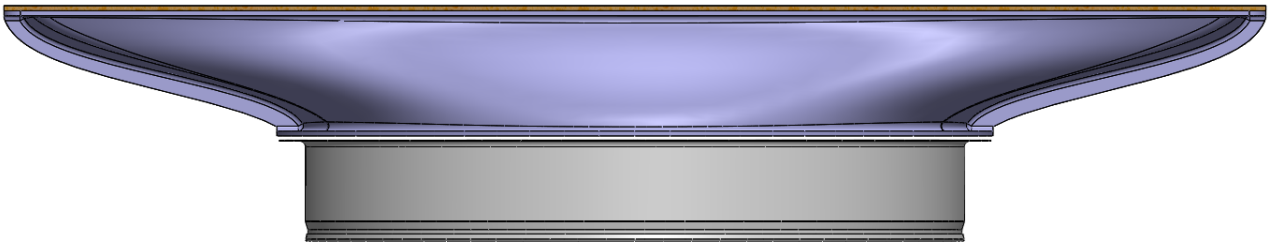

Figure 63 - 400mm duct spigot variant.

300mm

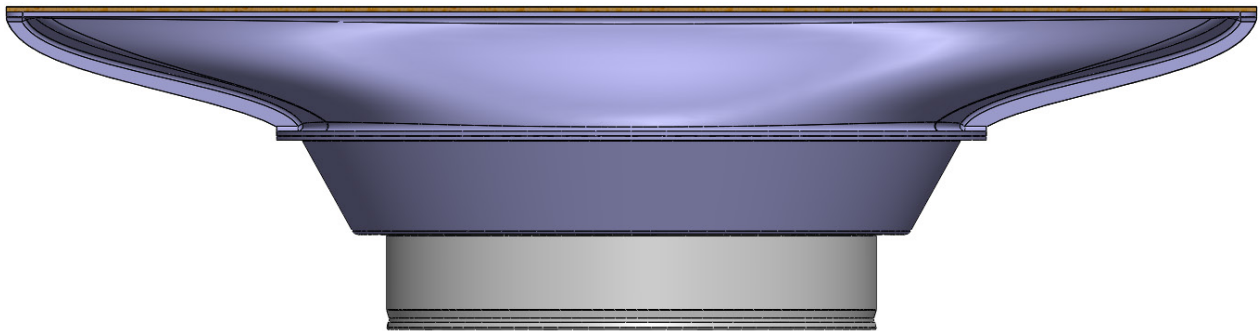

Figure 64 - 300mm duct spigot variant.

250mm

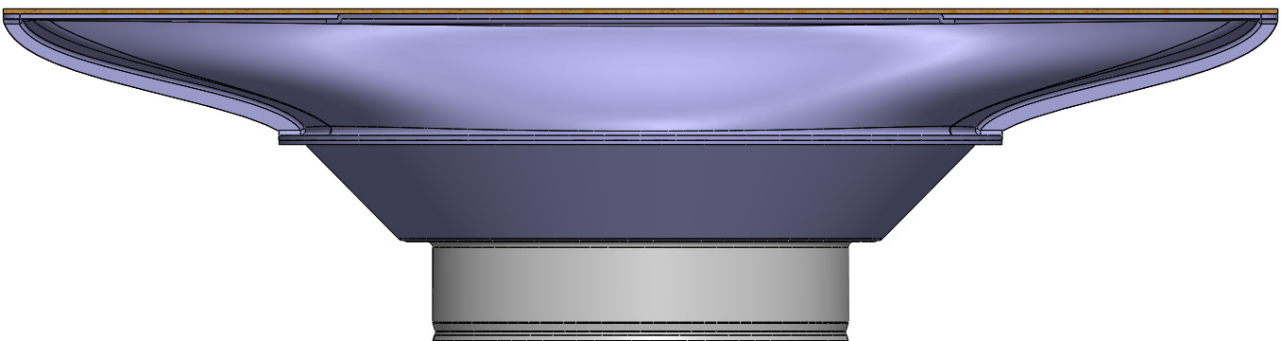

Figure 65 - 250mm duct spigot variant.

16. Ventive Hub Controls

The Ventive Hub controls unit comes complete with CO2 sensors, outdoor temperature sensor and a central control system. The central control system is programmed by Ventive with the parameters specific for your project. It is supplied with a GSM router so we are able to monitor the CO2 and temperature within each classroom and other occupied spaces whilst also reading external temperatures at the same time. Data from these sensors are recorded so Ventive can monitor the indoor air quality within each space and change or amend the parameters as required.

The Ventive Hub controls unit should be installed by a qualified electrician. A wiring diagram specific to your project will be provided by Ventive, you can see a typical wiring diagram in section 16.3 on page 53 for your reference.

Positioning Recommendations for the sensors

CO2 sensors should be installed internally:

- Positioned 1.2m above FFL
- Away from heating/cooling sources
- Away from spaces exposed to direct sunlight

Temperature Sensor should be installed externally:

- Positioned an high level
- Out of direct sunlight
- Away from spaces exposed to direct sunlight

Please note: sensors should stay in their box until the site is dust free OR ensure the sensors are suitably sealed (including the sides, top and bottom vents after mounting them to ensure they remain dust free. If sealed please remove the seal before going live.

16.1 CO2 Sensor

The Ventive Windhive range CO2 Sensor is designed to detect Carbon Dioxide concentration and temperature in classrooms and other occupied spaces. The units have "traffic lights" for alarm functionality set to Green (below 1500ppm; Amber (between 1500ppm and 2000ppm and Red (above 2000ppm, as prescribed by BB101. The CO₂ sensor calibrates automatically. The sensors have linear 0 to 10V signal outputs relating to CO₂ concentration that can also be linked to temperature and humidity.

The sensors should be installed directly onto a wall mounted box in a dry indoor environment and 1.2 metres high. The built-in controller allows ventilation to be boosted automatically when CO₂ levels exceed 1500ppm.



Figure 66 - CO2 controller.

Technical Data

Power Supply		24Vac/dc -10%/+15%, max 1VA
Displays and Interfaces	Alarm LEDs (Traffic Lights)	Green, Yellow and Red LEDs. Alarm limits adjustable (Default: CO ₂ Amber: 1500ppm, CO ₂ Red: 2000 ppm)
	Push Button	Timed Bypass Override
Signal Outputs	Analog	Up to 4 0..10Vdc < 5mA; 100k min impedance for 1% accuracy
	Option	2 x 24Vac Triacs; 2A maximum; Requires 24Vac Power Supply
Connections	Terminal Connections	Solid and Stranded Cable; 55° Angle for Wiring; Cable Size: 0.05 to 1.5mm ² (EN ISO; Rising Clamp: Size 2.5 x 1.9mm
Environmental Conditions	Temperature	0°C...+50°C (32..122°F)
	Degree of Protection	IP20
Housing	Material	ABS Plastics, Self-Extinguishing, RAL9010 Pure White
	Mounting	Wall or Junction Box Mounting
	Dimensions	W86 x H120 x D29mm

Sensing Characteristics

Carbon Dioxide (CO2	Range	0...5000ppm CO2 (Range Adjustable
	Accuracy	± 50ppm + 3% of the reading @ 25°C (@77°F
	Technology	Auto Calibrating; Non-Dispersive Infrared (NDIR
	Non-Linearity	<1% FS
	Warm-Up Time	<20 seconds
	Response Time	2 minutes
Temperature (option	Range	0..50°C (32..122°F
	Accuracy	±0.3°C
Humidity - RH (option	Range	0..100%rH
	Accuracy	±2% RH (within 0..90% RH

Connections

Wiring Terminals	D01	Digital Output; 24Vac Triac Switching to 0V; max. 2A (option
	D02	Digital Output; 24Vac Triac Switching to 0V; max. 2A (option
	G	24Vac/dc Power Supply
	G0	0V Common
	Y1	0..10Vdc Analogue Output (Function Selectable, default CO2
	Y2	0..10Vdc Analogue Output
	Y3	0..10Vdc Analogue Output
	G0	0V Common

16.2 External Temperature Sensor

The Ventive Windhive range temperature sensors are designed to detect outdoor temperature. Housing is made of weather-proof plastic. The screw cover and the terminal blocks tilted to 45° make an easy installation.

Temperature is detected by a range of thermistors and resistive elements with nominal resistances.

Sensor is mounted on the wall by means of screws through the mounting brackets on either side of the sensor, or through the installation entries inside the enclosure.



Figure 67 – Outdoor Temperature Sensor.

Technical Data

Senor Element	TEU 1000 - 1000Ω PTC thermistor TEU PT1000 - Pt1000 EN 60751/B TEU NTC10 - 10kΩ NTC thermistor TEU NTC20 - 20kΩ NTC thermistor TEU NTC1800 - 1800kΩ NTC thermistor TEU NI1000-LG - Ni1000-LG TEU NTC10-KB - Linearised 10kΩ NTC thermistor TEU NTC10-AN - 10k4A1 NTC thermistor
Accuracy	TEU 1000 - ±1.3°C (at 25°C) TEU PT1000 - ±0.3°C (at 0°C) TEU NTC10, TEU NTC20, TEU NTC10-AN & TEU NTC1800 - ±0.2°C (at 25°C) TEU NI1000-LG - ±0.5°C (at 0°C) TEU NTC10-KB - ±0.3°C (at 25°C)
Housing	plastic (<120°C)
Protection class	IP 54, cable entry
Cable entry	M16
Range	-50°C...+120°C

16.3 Wiring Detail

Key

Controller wiring: RS458

Power & supply wiring: 6 core 0.75mm²

1 core (part of the 6 core cable)

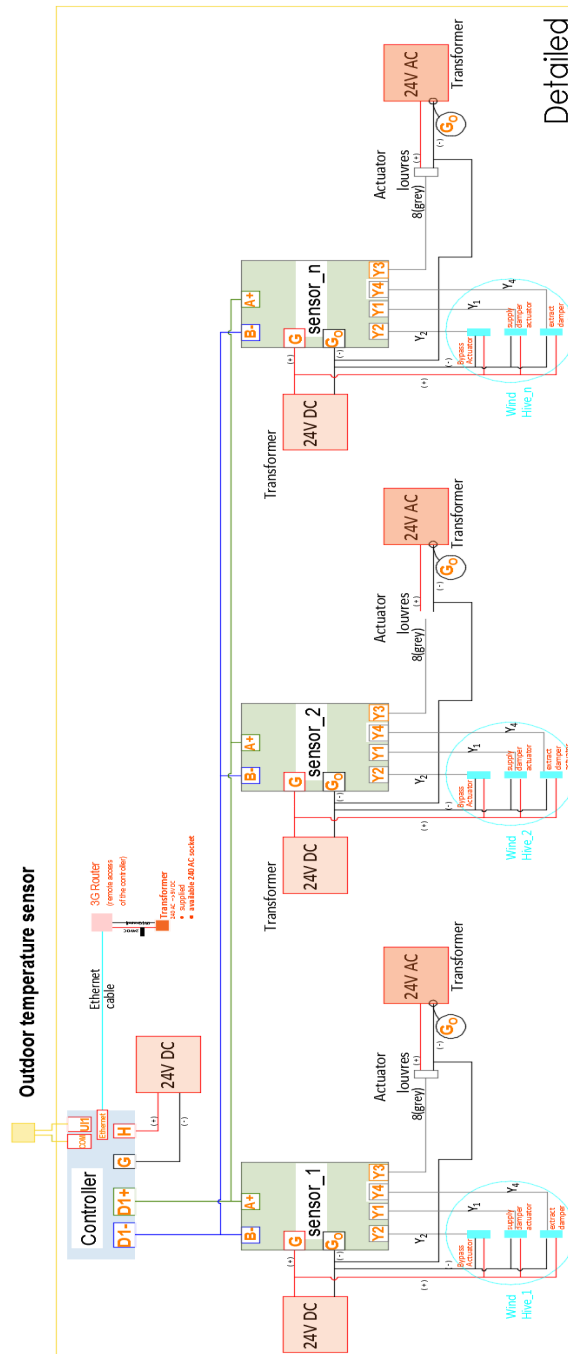

Figure 68 – Windhive wiring schematic.

17. Post - installation Checklist of Ventive Windhive

17.1 Above Roof

17.1.1	Cowl is fixed firm and vertical. Ensure fixings in place and watertight	
17.1.2	Roof flashing properly placed	
17.1.3	Check all items secure before leaving roof area	
17.1.4	No damage to existing roof	
17.1.5	Photograph cowl connection and flashing detail	

17.2 Below Roof

17.2.1	Roof penetration is watertight and checked	
17.2.2	System mounted vertically	
17.2.3	Flow splitter fixed and secured to Heat Exchanger	
17.2.4	Ducting fixed to flow splitter (where specified	
17.2.5	Flow splitter condensate drains connected firmly and securely to the building's foul or rain water drainage system. Clear of any debris and watertight.	
17.2.6	Flow splitter fixed correctly and secured to duct system and insulated properly (if not in insulated space	
17.2.7	Ensure all ducting and parts in the uninsulated space are insulated	
17.2.8	All fabric penetrations airtight	

17.3 Ducted – Within Building Envelope

17.3.1	All duct joints taped and fixed securely	
17.3.2	Inlet/outlet ducts fixed to vent/diffusers	
17.3.3	The supply and exhaust valves must be fully opened prior to commissioning	
17.3.4	All electrical connections for the CO2 sensor, control and actuator are in place (if used	

Installer signature:

Company name:

Contact details:

18. Commissioning

1. The installation can be commissioned when all ducts are fitted and the building envelope is completed.
2. **To do so:** Close all doors and windows and conduct a smoke test at each terminal.
Please note that if airtightness is lower than recommended, air-supply will be more wind-dependant. For optimum operation, air-tightness should be better than $5\text{m}^3/\text{m}^2 \text{ h}$ at 50Pa (for further details see the specification guidance of Ventive.

19. Installer Details

Your Ventive Windhive was installed by:

Company Name:

Installer Name:

Company / Installer contact details:

Email address:

Date of test and check.....

Installer signature:



Technical Support: +44 (0208 560 1314

Ventive Ltd

Thames House

Swan Street, Old Isleworth

TW7 6RS

London

www.ventive.co.uk

support@ventive.co.uk